

One of Hyson Products' controllable manifold systems, the DRAC® Positive Lock Delayed Return System is engineered for use in metal stamping applications that require a delayed return of the pressure pad. It is a nitrogen manifold system that incorporates three types of cylinders, each performing a specific task.

Delay cylinders operate as standard nitrogen cylinders, providing force on the pad in the die.

Priming cylinders make contact with the ram shortly after the ram makes contact with the die pad or draw ring. Priming cylinders require direct contact with the ram but do not affect pad pressure.

Timing cylinders are also in direct contact with the ram but do not affect the pressure on the die pad or draw ring. Activated by a Tanker® XP cylinder attached to the ram of the press, timing cylinders provide lockdown without springback.

The DRAC® Positive Lock Delayed Return System is designed for lower applications.

The DRAC® Positive Lock Delayed Return System offers these advantages and more!

- Full pad lockdown/pull away capability
- Full force on contact
- Consistent forming pressure
- No valves to adjust
- No need for external accumulators, tanks, and hoses
- User-adjustable dwell time
- User-adjustable speed return
- Multiple actions from a single action press
- Reduction of redraw operations

To find out how controllable manifold system technology can improve the efficiency, flexibility, and reduce stress-related downtime in your metal stamping operations, contact Hyson Products today at 800-876-4976 or 440-526-5900!

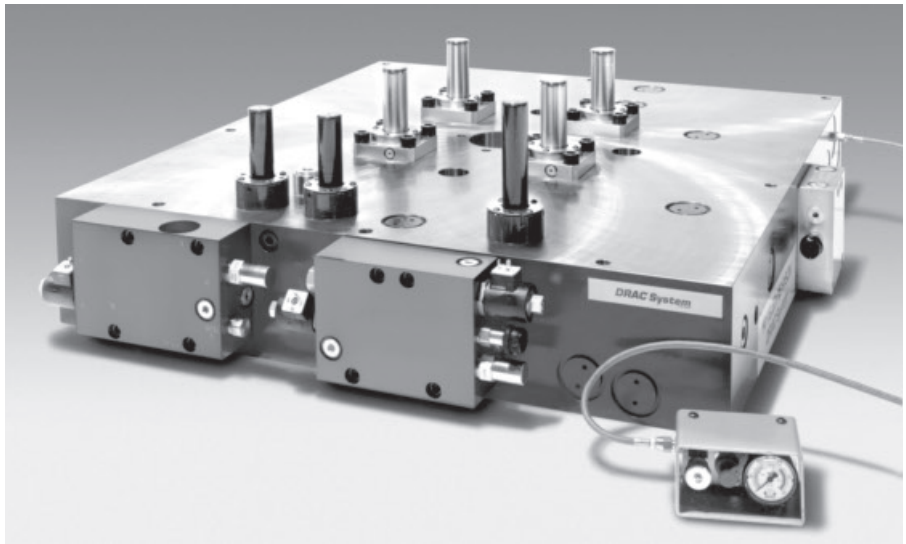

How It Works

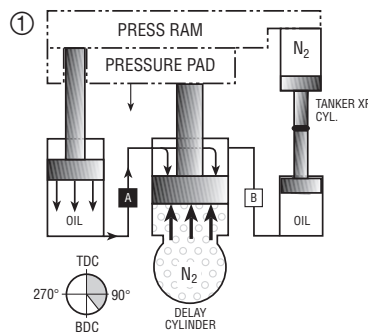

As press ram comes down, oil from prime cylinder is pumped into top side of delay cylinder.

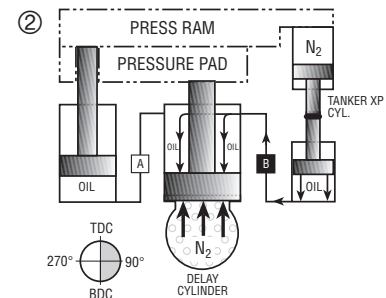

At or near bdc, valve B opens, allowing Tanker XP cylinder to extend, depressing timing cylinder which pumps oil into top side of delay cylinder. This achieves lockdown, zero pressure exerted on pad from delay cylinder.

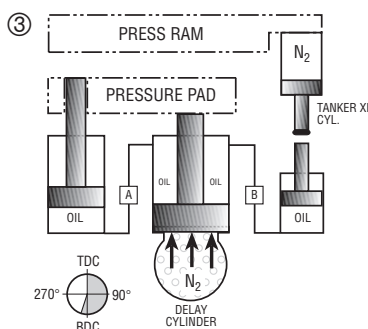

As press ram goes up, delay cylinder and pressure pad remain in lockdown position.

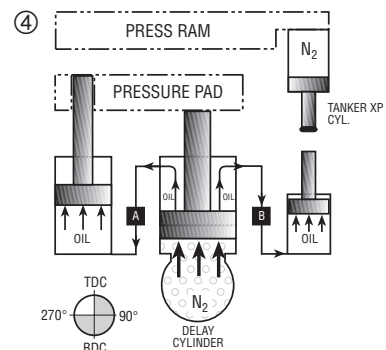

At a customer-determined point in press stroke, valves A & B open, allowing fluid from top side of delay cylinder to return to prime and timing cylinders.



Designing a DRAC® Positive Lock Delayed Return System

This example is provided as a guideline only. To determine actual system dimensions, complete the application data sheet and return to Hyson Products' Customer Service Department.

Design Sequence:

1. Min. number of cylinders = forming tonnage required divided by cylinder force divided by 0.88.
2. Min. manifold volume = number of cylinders x cylinder force x cylinder stroke x volume factor (see Table A).
3. Manifold thickness = 88.9 mm (3.50 in.) + cylinder stroke. Min. thickness is 152.4 mm (6.0 in.).
4. Manifold volume divided by manifold thickness = A x B (see System View).
5. Manifold volume is calculated in mm³ or in³.

Table A - Volume Factor									
Stroke Cylinder Force	12.7 mm 0.5 in.	25.4 mm 1.0 in.	50.8 mm 2.0 in.	76.2 mm 3.0 in.	101.6 mm 4.0 in.	127.0 mm 5.0 in.	152.4 mm 6.0 in.	177.8 mm 7.0 in.	203.2 mm 8.0 in.
22.2 kN 2.5 Ton	71,775 990	42,413 585	23,200 320	20,373 281	21,750 300	22,838 315	23,635 326	24,505 338	25,158 347
53.4 kN 6.0 Ton	51,258 707	31,683 437	18,633 257	16,313 225	17,400 240	18,270 252	19,068 263	19,720 272	20,228 279

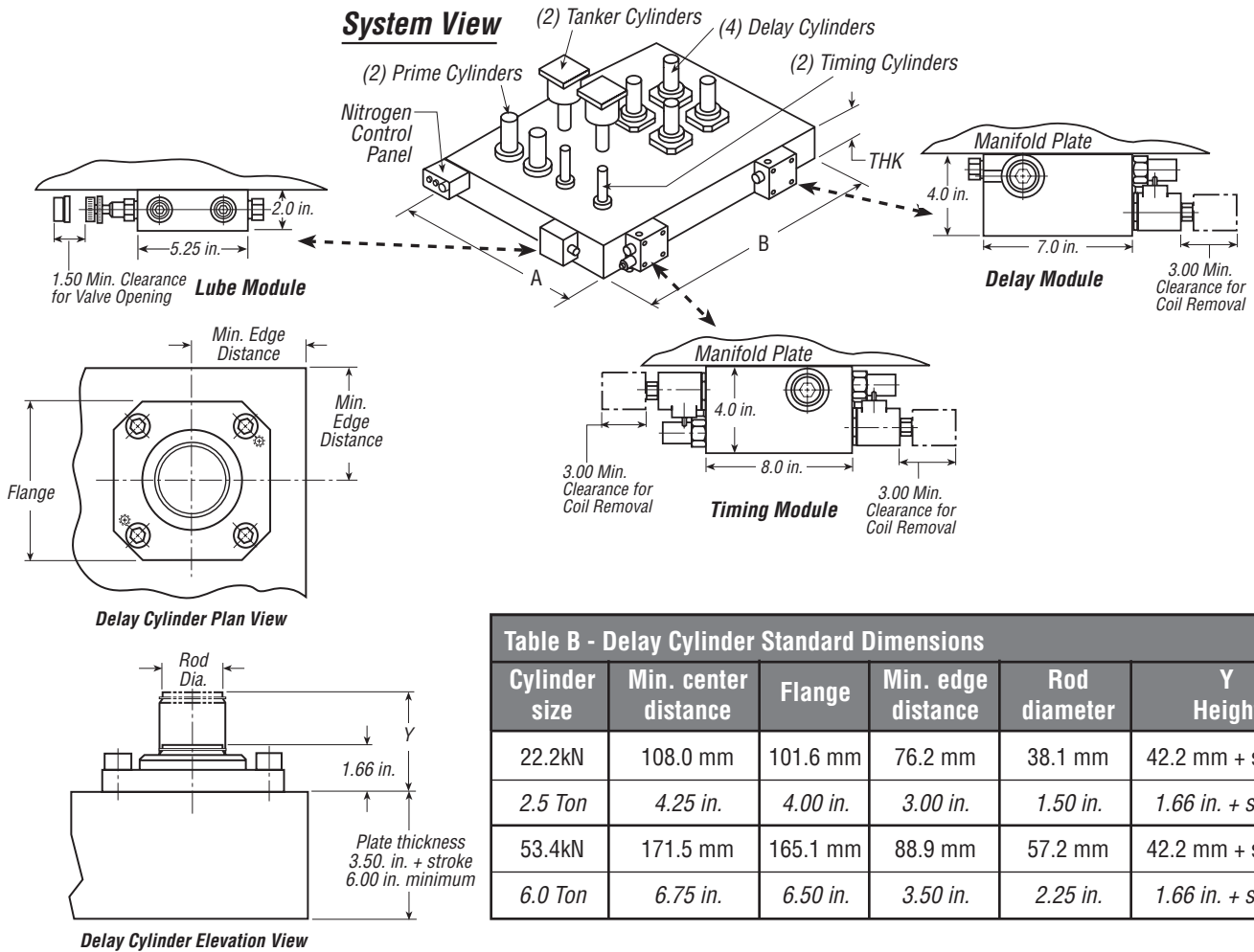

Table B - Delay Cylinder Standard Dimensions					
Cylinder size	Min. center distance	Flange	Min. edge distance	Rod diameter	Y Height
22.2kN 2.5 Ton	108.0 mm 4.25 in.	101.6 mm 4.00 in.	76.2 mm 3.00 in.	38.1 mm 1.50 in.	42.2 mm + stroke 1.66 in. + stroke
53.4kN 6.0 Ton	171.5 mm 6.75 in.	165.1 mm 6.50 in.	88.9 mm 3.50 in.	57.2 mm 2.25 in.	42.2 mm + stroke 1.66 in. + stroke

Note: All dimensions are nominal unless tolerance is stated. Data shown are typical. Actual data for any particular unit may vary from those shown here.

