

Hyson® Products

Associated Spring 

DRAC® 2 SOFT LOCK DELAYED RETURN SYSTEM P/N SOFTLOCKINST

Many of the processes and components of this system are covered under U.S. Patents No. 5,007,272 and 5,003,807. Other Patents are pending.

Rev. 1.4 7/06
©Hyson Products 2006

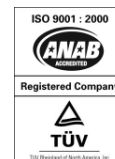

NOTICE TO CUSTOMERS;

It is important that **All** personnel involved in the installation, operation, and maintenance of the Hyson Products, Delay Return System, be familiar with the contents of this manual.

A general understanding of the System operation, and Troubleshooting techniques will maximize the service life and minimize downtime.

-Keep a copy of this manual at the press for operator reference.-

With proper usage and maintenance, the Delay unit should provide trouble-free service for the life of the die.

For extra copies of this Manual; call Hyson Products @ 1-800-876-4976, or call your local Sales Representative.

TABLE OF CONTENTS:

Section 1	4
GENERAL DESCRIPTION.....	4
How the System Works:.....	4
The "Delay Return" Cylinder;.....	4
Control;.....	4
Controlled Delay;.....	4
Section 2	8
SYSTEM HANDLING, INSTALLATION, AND REMOVAL.....	8
- WARNING! -	8
System Handling:	8
Delayed Return System Installation:.....	8
Prior to Try-out, verify;.....	9
Section 3	10
ELECTRICAL/TIMING REQUIREMENTS.....	10
- WARNING! -	10
Electrical Timing (Solenoid Switching):.....	10
SOLENOID COILS;	10
Timing Wheel.....	11
Electrical System Wiring (DR-ECM):	12
Section 4	14
NITROGEN CHARGING, DISCHARGING, & SYSTEM FORCE ADJUSTMENT.....	14
- WARNING! -	14
NITROGEN CHARGING:	14
Nitrogen Reservoir 14	
Fluid Reservoir 14	
System Force Adjustment:.....	15
Delay Manifold Force;	15
Increasing Force:.....	15
Decreasing Force:.....	15
Nitrogen Discharging (For Service):.....	16
Section 5	17
SYSTEM FLUID REQUIREMENTS.....	17
Checking the Fluid Level:	17
Adding Fluid:.....	17
- WARNING! -	17
Section 6	20
CUSHION RETURN, SPEED ADJUSTMENT.....	20
- WARNING! -	20
Section 7	21
SYSTEM MAINTENANCE & TROUBLESHOOTING.....	21
- WARNING! -	21
System Maintenance:.....	21
Delayed Return System Troubleshooting:.....	23
Component Torque Requirements;.....	24
System Start-up - Quick Reference	26

Section 1

GENERAL DESCRIPTION.

Delayed Return Technology, from Hyson Products, offers the first Nitrogen Gas Spring capable of motion, position, and force control, at any point and time.

By combining Fluid Power technology with the performance advantages of Nitrogen Gas Springs, featuring the Delay Return Cylinder, flexibility and performance for the die designer and metal stamper is available in a “self-contained” manifold package.

How the System Works:

The “Delay Return” Cylinder;

- The Delay Return cylinder is first and foremost, a Nitrogen Gas Spring. Gas pressure works on a sealed piston inside the cylinder, to provide force through the piston rod, exactly like a typical Nitrogen Gas Spring, such as the Hyson Products MOR style cylinder.
- The difference in the Delay Return from all other Nitrogen Gas Springs is the introduction of fluid to the rod side of the piston. A dual seal arrangement keeps the Nitrogen and Fluid mediums separate, allowing the cylinder function with the advantages of both technologies.

Control;

- Control of the Delay Return Cylinder is achieved through a Control Module mounted directly to the manifold plate, eliminating the need for bulky valve bodies, tanks, and hoses outside the die.
- The Control Module contains Solenoid and Speed Control valves. These valves are designed to allow for System flexibility and user control/adjustability.

Controlled Delay;

- A typical Delayed Return System consists of (1) manifold plate,(2) Delay Return Cylinders, (3) Control Module, (see illustration on following pages).

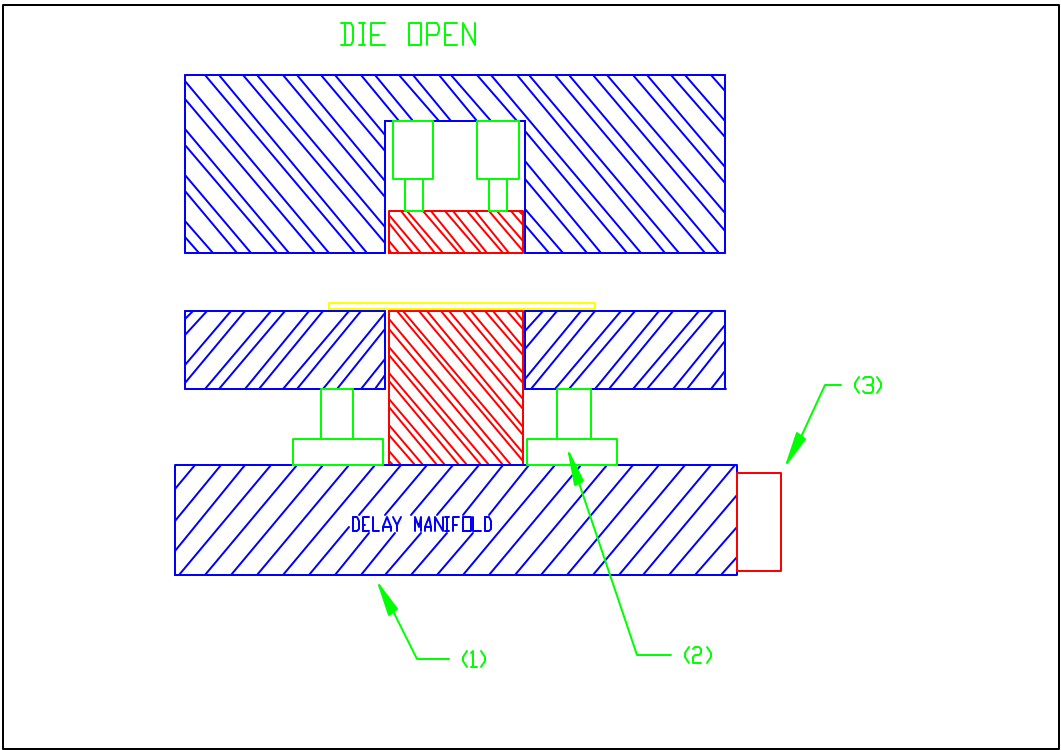

- Shortly after Top Dead Center (TDC) (for timing requirements, ref.: Section 3), the Solenoid valve is “energized” closed.
- As the upper and lower die halves make contact, full pad pressure is seen at the Delay Return Cylinder(2). The top of the Delay Return Cylinder is filled from the Accumulator.

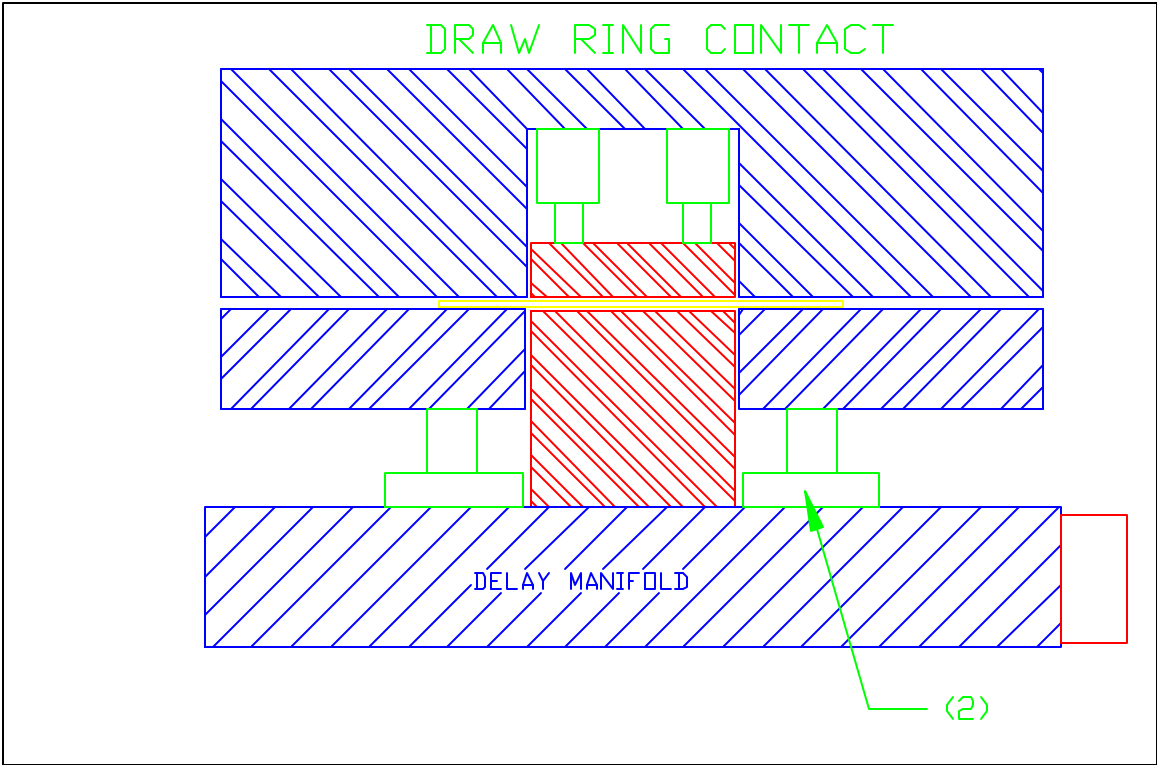

FORMING PART

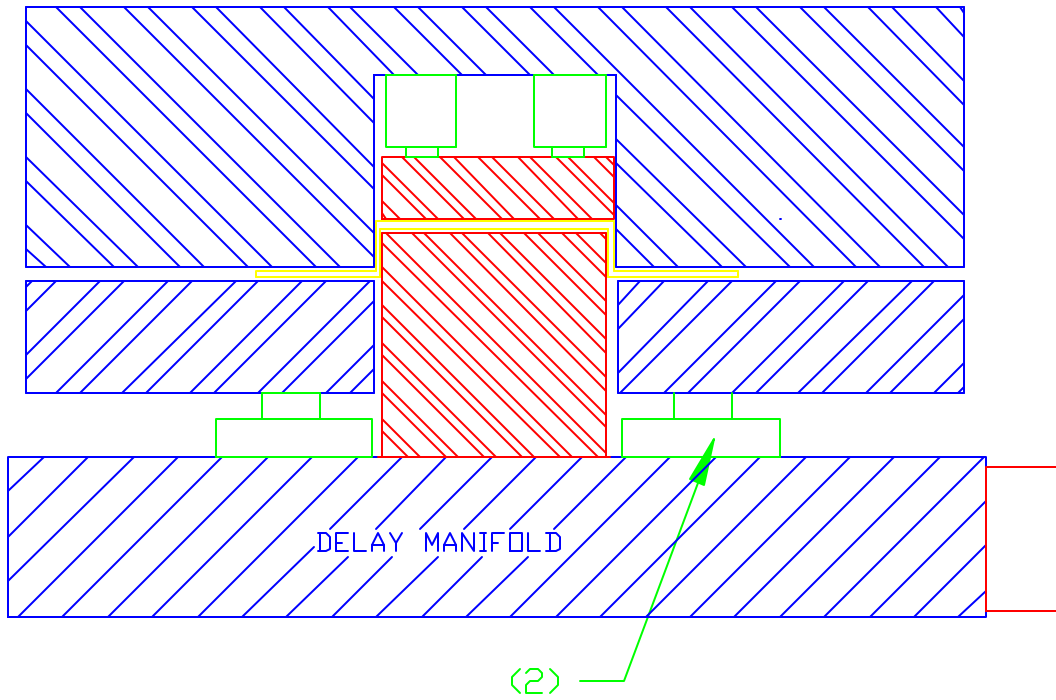

AT/NEAR BDC

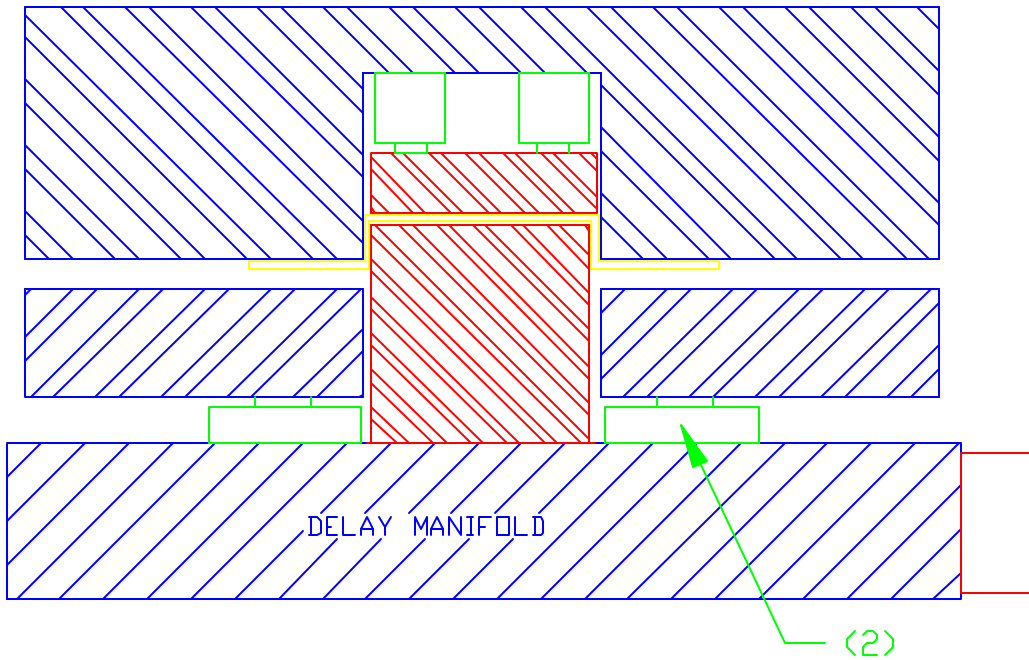

- As the upper and lower halves of the die separate, the Delay Return Cylinder (2), and Pressure Pad remain in the “locked down” position.

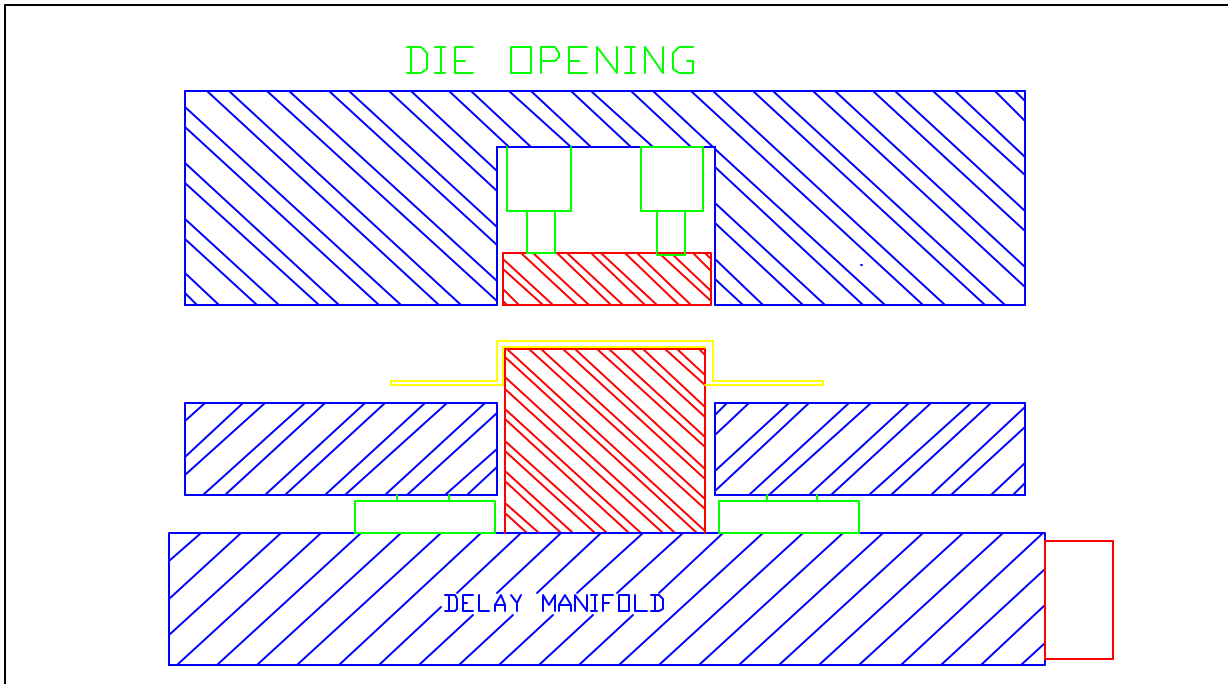

- At a pre-determined point in the press stroke (for timing requirements, ref.: Section 3), the Solenoid valve is de-energized open, allowing the fluid to be pumped out of the top side of the Delay Return Cylinder(2), back into the Accumulator and allowing the Pad to return to the die open position at a controlled rate (customer determined).

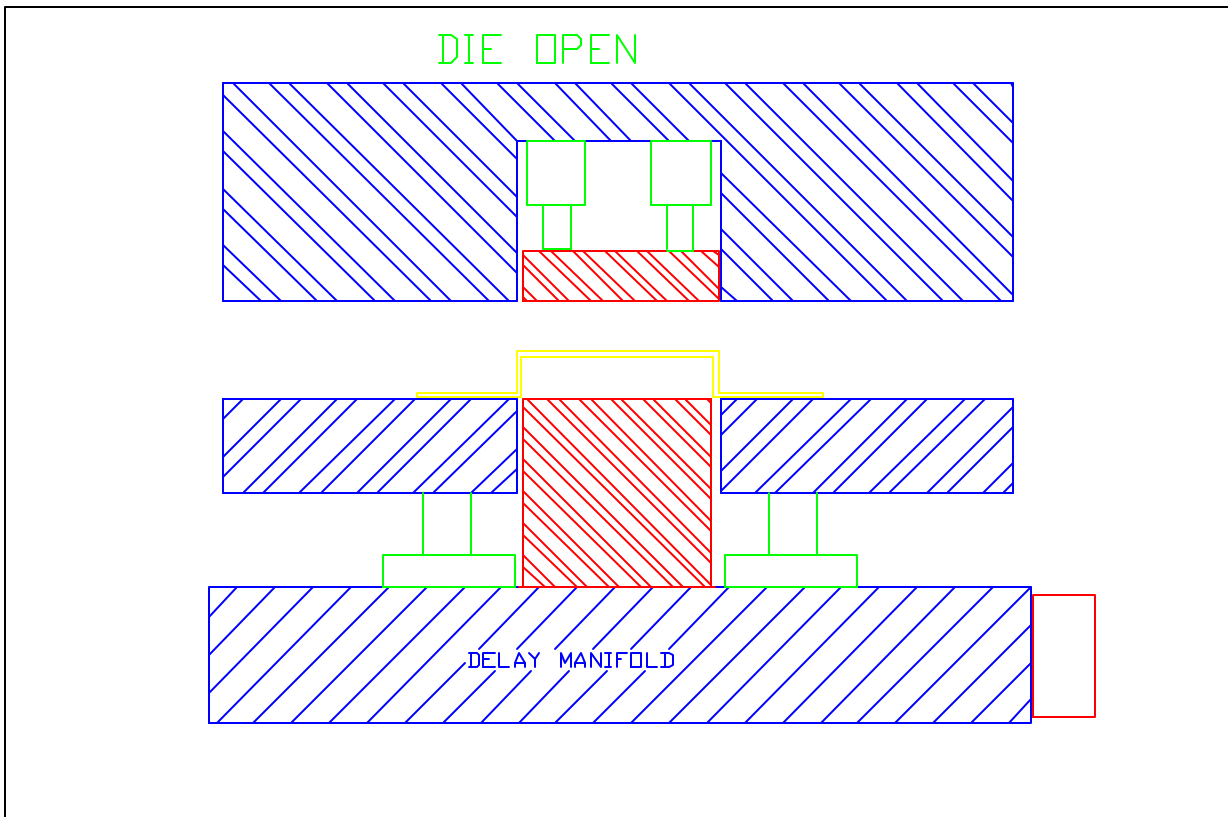

Section 2

SYSTEM HANDLING, INSTALLATION, AND REMOVAL.

- WARNING! -

As with any other equipment operating with pressurized gas, **ALWAYS;**

- Wear approved eye protection.
- Exhaust **ALL** Nitrogen gas from the unit before loosening any component.
- **DO NOT MACHINE OR DRILL INTO THE DELAY MANIFOLD FOR ANY REASON WITHOUT WRITTEN APPROVAL FROM HYSON PRODUCTS.**

System Handling:

Before handling, installing, or removing a delay return unit, discharge all nitrogen gas pressure, as described in section 4, Nitrogen Charging, Discharging, & System Force Adjustment.

Properly plug all open ports (ex: nitrogen charge port). This will eliminate the possibility of losing any fluid during transport, service, or installation.

Care should be taken to prevent damage to the Control Module(s), Cylinders and Accumulator(s) during handling/moving of the unit.

Delayed Return System Installation:

Inspect the unit for damage before installation (eg.: damaged Solenoid Valves, Cylinder Piston Rods, Accumulator..etc.).

Care should be taken to prevent damage to the Aluminum control Module(s) and Cylinders during installation of the die assembly.

Otherwise, procedures and precautions should be the same as for mounting any typical Hyson Products nitrogen manifold system. Questions ? Dial 1-800-876-4976.

Section 3

ELECTRICAL/TIMING REQUIREMENTS.

- WARNING! -

- Only Personnel with a thorough knowledge of electrical wiring should attempt to install, service, or repair the electrical components on this unit.
- Consult any national or local codes/requirements.
- Turn off **ALL** electrical power to the unit before attempting to connect or disconnect the wires to the electrical components.
- **DO NOT SUBSTITUTE** any components of any kind in this unit. Improper substitutions may result in performance and safety problems.

Electrical Timing (Solenoid Switching):

The signal to energize the Solenoid should be supplied by a cam switch or other arrangement, and be synchronized with the motion and position of the press crank. See page 11 for the suggested timing arrangement for the actuation of the switches and resulting delay action of the manifold system.

SOLENOID COIL(S);



The Solenoid Coil receives a 24 VDC input signal from the Dynamic Systems, Electronic Control Module. The Electronic Control Module converts the 120 VAC supply signal to 24 VDC.

DO NOT REMOVE SOLENOID COIL FROM VALVE. **DISCONNECT AT ELECTRICAL CONNECTION.**

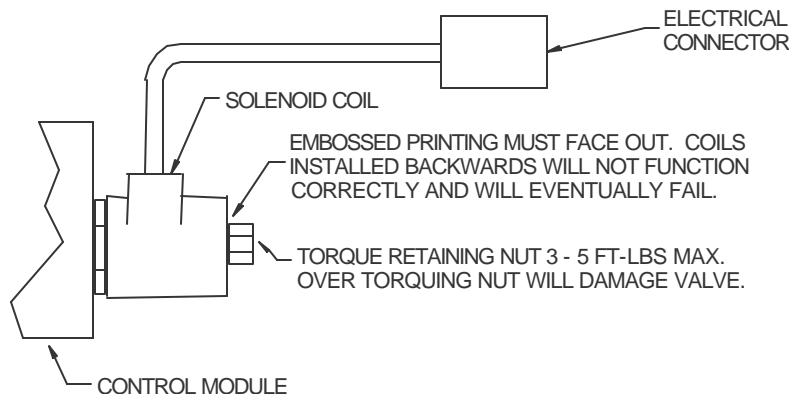
IF YOU MUST SERVICE THE SOLENOID USE THE FOLLOWING INSTRUCTIONS.

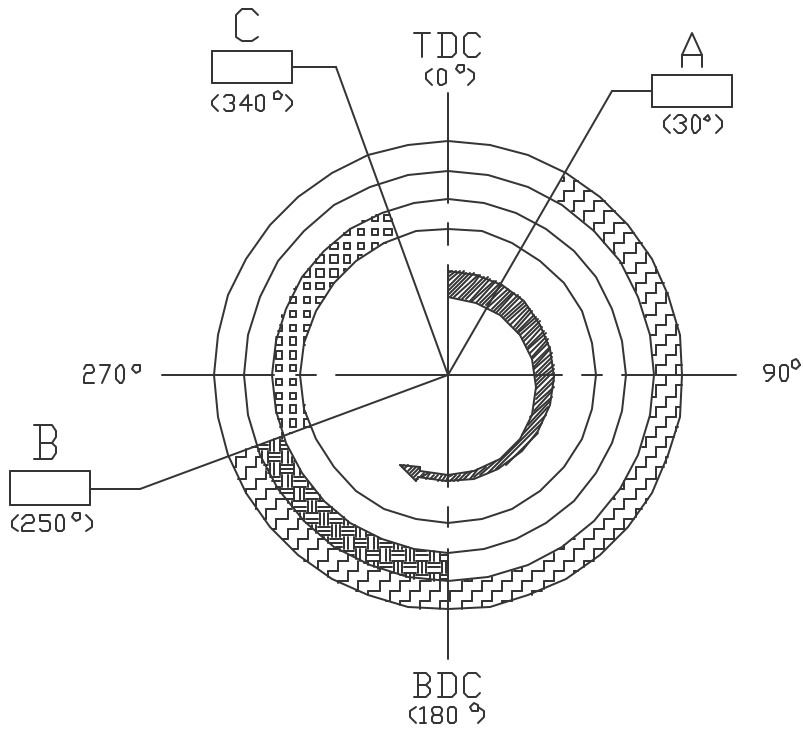



-  = SOL1 (Timing Solenoid).
 = Net Delay (Pad Locked Down)
 = Net Extend Time (Customer Determined).

A = Initiation of Timing Sequence. - Shortly after TDC.

[ENERGIZE SOLENOID]

BDC = "LOCKDOWN" Begins - Cushion force will start to drop to zero @ 180°.

B = Signal ends "DELAY". - Cushion force is re-applied.

- Cushion begins return to original position.

[DE-ENERGIZE SOLENOID]

C = Degrees in press rotation at which full cushion extension is required.

- For automation requirements.

NOTE: These numbers are only examples. Customer may choose their own timing.

Electrical System Wiring (DR-ECM):

The following is the suggested wiring diagram when using the Electronic Control Module (P/N: DR-ECM-1);

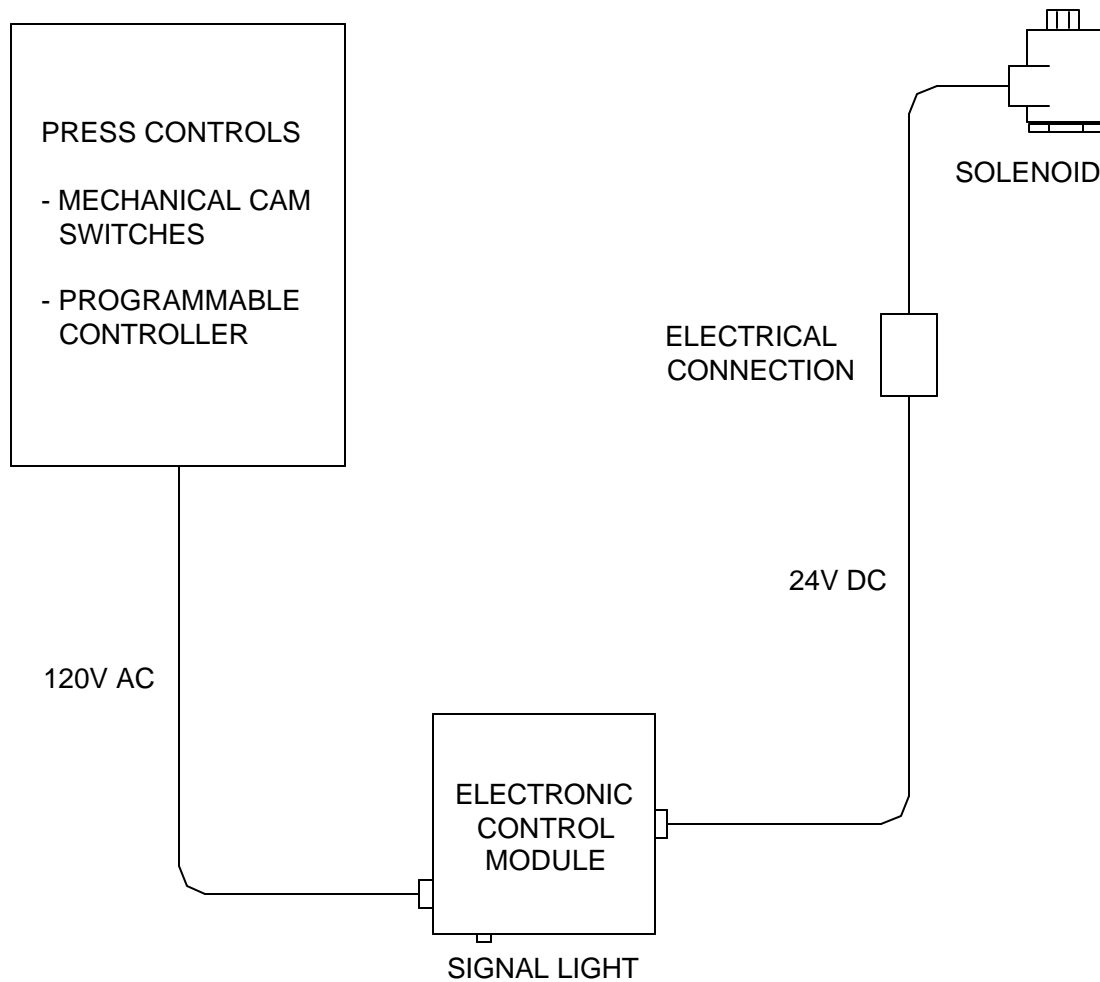

One (1) Signal of 120VAC is required from the press controls (for Timing Requirements, see previous page) for the Solenoid Valve.

- The cable from the press controls is attached to the Electronic Control Module using the Connectors provided with the unit.
- The Electronic Control Module is mounted to the die or press in an accessible location, with the signal light visible.
- Locate the solenoid per the System Approval Print provided with the unit. Route the solenoid coil cable from the coil to the Electronic Control Module and attach connectors provided.
- Plug solenoid coil cables into Electronic Control Module.

Section 4

NITROGEN CHARGING, DISCHARGING, & SYSTEM FORCE ADJUSTMENT.

-WARNING! -

As with any other equipment operating with pressurized gas, **ALWAYS**;

- Wear approved eye protection.
- Exhaust **ALL** Nitrogen gas from the unit before loosening any hose, fitting, or other component.

NOTE: Unless otherwise specified, all Delayed Return Manifolds are designed for a maximum (**Die Closed**) Nitrogen pressure of 1500 PSI (103 BAR).

NITROGEN CHARGING:

NOTE: Always fill the Nitrogen Reservoir **BEFORE** filling the Accumulator.

Nitrogen Reservoir

- Close the exhaust valve located on the **NITROGEN** Reservoir Control Panel.
- Make sure Solenoid Valve is **DE-ENERGIZED** (no power applied).
- Attach Nitrogen charge hose to the quick connect coupling located on the **NITROGEN** Reservoir Control Panel.
- Begin filling the system with Nitrogen.
- When the desired operating pressure is reached, shut off the Nitrogen gas flow, and disconnect the charging hose.

Accumulator

- Close the exhaust valve located on the **ACCUMULATOR** Control Panel.
- Make sure Solenoid Valve is **DE-ENERGIZED** (no power applied).

- Attach Nitrogen charge hose to the quick connect coupling located on the **ACCUMULATOR** Control Panel. **SLOWLY** begin to fill the system with Nitrogen.
- When the maximum operating pressure of 300 PSI is reached, shut off the Nitrogen gas flow, and disconnect the charging hose.

System Force Adjustment:

Delay Manifold Force;

The method for adjusting the force exerted on the die by the Drac Cylinders is the same as for any standard Hyson Products Nitrogen Manifold system. A good “rule - of - thumb” is to use the lowest charge pressure that is necessary to achieve a good part. This will provide the longest service life of all components, as well as minimize stress and wear on the press.

Increasing Force:

- Adjustments should be made **die open**.
- Make sure the exhaust valve located on the **NITROGEN** Reservoir Control Panel is closed.
- Make sure Solenoid Valve is **DE-ENERGIZED** (no power applied).
- Attach Nitrogen charge hose to the quick connect coupling located on the **NITROGEN** Reservoir Control Panel. **SLOWLY** begin to increase the Nitrogen pressure.
- When the desired operating pressure is reached, shut off the Nitrogen gas flow, and disconnect the charging hose.
- **DO NOT** adjust the **ACCUMULATOR** pressure.

Decreasing Force:

- Adjustments should be made die open.
- Make sure Solenoid Valve is **DE-ENERGIZED** (no power applied).

- **SLOWLY** open the exhaust valve located on the **NITROGEN** Reservoir Control Panel.
- When the desired operating pressure is reached, close the exhaust valve.
- **DO NOT** adjust the **ACCUMULATOR** pressure.

Nitrogen Discharging (For Service):

NOTE: Always discharge the Accumulator completely **BEFORE** discharging the Nitrogen Reservoir.

- Make sure Solenoid Valve is **DE-ENERGIZED** (no power applied).
- **SLOWLY** open the exhaust valve located on the **ACCUMULATOR** Control Panel.
- As the Nitrogen pressure drops, the exhaust valve located on the **ACCUMULATOR** Control Panel can be incrementally opened further.
- Once the gauge on the **ACCUMULATOR** Panel reads zero (0), open the exhaust valve fully.
- **SLOWLY** open the exhaust valve located on the **NITROGEN** Reservoir Control Panel.
- As the Nitrogen pressure drops, the exhaust valve located on the **NITROGEN** Reservoir Control Panel can be incrementally opened further.
- Once the gauge on the **NITROGEN** Reservoir Control Panel reads zero (0), open the exhaust valve fully. Verify that ALL of the Nitrogen pressure is gone by depressing all of the cylinder rods.

Section 5

SYSTEM FLUID REQUIREMENTS.

Checking the Fluid Level:

Should the need arise to verify the level of Fluid in the system;

- The manifold must be oriented in the correct operating position. If this is a lower system, the manifold is to be placed so that the Delay Cylinder piston rods are pointing up. If this is an upper system, the Delay Cylinder piston rods are to point down.
- The manifold **MUST** be level.
- Make sure the Solenoid Valve is De-energized (No Power Applied)
- Charge the Nitrogen Reservoir with Nitrogen to at least **500 PSI**. Charge the Accumulator with Nitrogen to **300 PSI**. Reference section 4, "Nitrogen Charging, Discharging, & System Force Adjustment."
- Discharge the Nitrogen Reservoir until all of the cylinder piston rods fully retract. The Accumulator pressure should lower to 100 to 125 psi.
 1. If all the piston rods do not retract, even though the Nitrogen Pressure has been completely removed, fluid must be added.
 2. If the piston rods retract and the pressure either does not lower or only lowers to 250 psi, fluid must be added.

Adding Fluid To Delay Systems:

-WARNING! -

As with any other equipment operating with pressurized gas, **ALWAYS**;

- Wear approved eye protection.
- Exhaust **ALL** Nitrogen gas from the unit before loosening any hose, fitting, or other component.
- Use **ONLY** P/N: DR-1900 Fluid in this system.

This unit is a "closed system" that, under normal operations, should not require the addition of Fluid on any regular basis. Any sign of a Fluid leak or a change in the Fluid level should be investigated, and if necessary, the entire system serviced.

- Make sure the Solenoid Valve is De-energized (No Power Applied)

For Delay Systems with a Fill Fitting:

- Charge the Nitrogen Reservoir with Nitrogen to at least **500 PSI**. Charge the Accumulator with Nitrogen to **100 PSI**. Reference section 4, “Nitrogen Charging, Discharging, & System Force Adjustment.”
- Locate the Fluid “Fill Fitting” (reference the system assembly print provided with the unit). **SLOWLY** remove the cap on the fitting. If any pressure is felt on the cap, or, gas or Fluid begins to leak out, **STOP IMMEDIATELY!**; and verify that the Nitrogen gas has been completely discharged.
- Make sure the pump is full of oil. Use only Hyson Fluid, P/N: DR-1900 (**DO NOT SUBSTITUTE!**).
- Attach the pump to the fill fitting. Add DR-1900 oil until the accumulator pressure is 300 psi. Frequently check the pump to make sure it does not run out of oil. **DO NOT PUMP AIR INTO THE SYSTEM.**

CAUTION: If the pressure does not increase as you are adding oil, STOP. The accumulator is full. Additional oil will cause the cylinder piston rods to retract.

- Remove pump and Replace Fluid “Fill Fitting” cap.
- Follow “Checking the Fluid Level” instructions above to verify that the proper amount of Fluid has been added.

For Delay Systems without Fill Fitting:

- Locate the Fluid “Fill Port” (reference the system assembly print provided with the unit). **SLOWLY** remove the plug. If any pressure is felt on the plug, or, gas or Fluid begins to leak out, **STOP IMMEDIATELY!**; and verify that the Nitrogen gas has been completely discharged.
- Install a port adapter fitting as quickly as possible to keep air from entering into the system to a minimum.
- Attach pump to port adapter fitting.
- Charge the Nitrogen Reservoir with Nitrogen to at least **500 PSI**. Charge the Accumulator with Nitrogen to **100 PSI**. Reference section 4, “Nitrogen Charging, Discharging, & System Force Adjustment.”
- Make sure the pump is full of oil. Use only Hyson Fluid, P/N: DR-1900 (**DO NOT SUBSTITUTE!**).

Section 6

CUSHION RETURN, SPEED ADJUSTMENT.

-WARNING! -

- **NEVER WORK ON OR NEAR THE DIE WHEN THE DELAY UNIT SOLENOID IS ENERGIZED, AND THE CUSHION IS LOCKED DOWN! ANY POWER INTERRUPTION OR COMPONENT FAILURE MAY RESULT IN EQUIPMENT DAMAGE AND/OR SERIOUS PERSONAL INJURY!**
- **WHEN IN DOUBT AS TO THE CONDITION OF THE DELAY UNIT BEING LOCKED DOWN OR NOT, DISCHARGE ALL NITROGEN PRESSURE GAS FROM BOTH THE NITROGEN AND FLUID RESERVOIRS.**
- **ALWAYS DISCHARGE ALL NITROGEN PRESSURE FROM BOTH RESERVOIRS BEFORE ATTEMPTING ANY TYPE OF REPAIR OR SERVICE, ON OR NEAR THE SYSTEM.**

This unit has “fixed” speed control cartridges; it is not adjustable during operation. To change the speed of the cushion return, it is necessary to change the speed control cartridges.

NOTE: In most cases, the “Release Point” (Signal “B” on the Timing Wheel in section 3 “Electrical/Timing Requirements”) can be adjusted. The Speed Controls should be changed as a last resort.

Should it become necessary to change the Speed Control Cartridges, consult Hyson Products to determine the proper cartridge sizing. Before calling, determine the following;

- Observe the time (in degrees or seconds) it takes for the pad to return once the solenoid is de-energized (Signal “B”). Record this time.
- Determine the time (in degrees or seconds) required.
- Record the serial number of the unit.
- Contact Hyson Products, or your sales representative, with this information. The proper Speed Controls will be calculated, & shipped.

Section 7

SYSTEM MAINTENANCE & TROUBLESHOOTING.

- WARNING! -

- **NEVER WORK ON OR NEAR THE DIE WHEN THE DELAY UNIT SOLENOID IS ENERGIZED, AND THE CUSHION IS LOCKED DOWN! ANY POWER INTERRUPTION OR COMPONENT FAILURE MAY RESULT IN EQUIPMENT DAMAGE AND/OR SERIOUS PERSONAL INJURY!**
- **WHEN IN DOUBT AS TO THE CONDITION OF THE DELAY UNIT BEING LOCKED DOWN OR NOT, DISCHARGE ALL NITROGEN GAS PRESSURE FROM BOTH THE NITROGEN AND FLUID RESERVOIRS.**
- **ALWAYS DISCHARGE ALL NITROGEN PRESSURE FROM THE RESERVOIRS BEFORE ATTEMPTING ANY TYPE OF REPAIR OR SERVICE, ON OR NEAR THE SYSTEM.**

System Maintenance:

Changing Fluid

- It should not be necessary to change the Fluid under normal operating conditions, unless there is a component failure or general system overhaul.

Rebuilding Cylinders

- Should one (1) cylinder require a rebuild, it is recommended that ALL Cylinders be rebuilt at the same time. It is less costly in the long run. It is also highly recommended to replace the Fluid at this time as well, to remove any contamination that may have resulted from a component failure.

Grinding Dust

- The Cylinders and other components in this unit are constructed of the highest quality materials available. However, like most equipment used in this type of environment, they are not impervious to the effects and damage caused by grinding grit and dust, introduced during die try-out and/or maintenance.

Delayed Return System Troubleshooting:

DELAYED RETURN TROUBLESHOOTING GUIDE:

SYMPTOM	POSSIBLE CAUSE	CORRECTIVE ACTION
NO LOCK - DOWN OR DELAY (PAD RETURNS WITH RAM).	- NO POWER TO SOLENOIDS. (NOT "PLUGGED IN")	- CONNECT POWER SUPPLY FROM PRESS (TO SIGNAL VOLTAGE).
	- SOLENOID COIL FAILURE.	- TEST FOR MAGNETISM, REPLACE.
	- COIL INSTALLED BACKWARDS.	- INSTALL WITH EMBOSSED PRINTING FACING OUT.
	- ELECTRONIC CONTROL MODULE (DR-ECM) FAILURE.	- CHECK INPUT (120VAC), AND OUTPUT (24VDC) VOLTAGE, REPLACE UNIT.
	-- DELAY CYLINDER SEAL FAILURE.	-- RE-BUILD CYLINDERS W/PROPER SEAL KIT.
PAD DRIFT - PAD DELAYS, BUT DRIFTS UP SLOWLY	- DELAY CYLINDER SEAL FAILURE.	- RE-BUILD CYLINDERS W/PROPER SEAL KIT.
SPRINGBACK LARGER THAN ACCEPTABLE.	- N ₂ IN FLUID LINES.	-- BLEED NITROGEN FROM SYSTEM
	- DELAY CYLINDER SEAL FAILURE.	- RE-BUILD CYLINDERS W/PROPER SEAL KIT.
PAD RETURNS TOO QUICKLY	- FLOW CONTROLS INCORRECTLY CALCULATED FOR RETURN RATE.	- TRY ADJUSTING RELEASE POINT (SET TO RETURN LATER)
		- RE-CALCULATE FLOW CONTROL REQUIREMENTS (REPLACE).
PAD RETURNS TOO SLOWLY	- FLOW CONTROLS INCORRECTLY CALCULATED FOR RETURN RATE.	- TRY ADJUSTING RELEASE POINT (SET TO RETURN EARLIER)
		- RE-CALCULATE FLOW CONTROL REQUIREMENTS (REPLACE).
FLUID LEAK	O-RING OR OTHER SEAL FAILURE	DISCHARGE ALL NITROGEN GAS PRESSURE. LOCATE AND REPAIR FAULTY COMPONENT.
FLUID (FOAM) DISCHARGE FROM NITROGEN CONTROL PANEL BLEED VALVE.	- DELAY CYLINDER SEAL FAILURE.	- RE-BUILD CYLINDERS W/PROPER SEAL KIT.
FLUID (FOAM) DISCHARGE FROM ACCUMULATOR CONTROL PANEL BLEED VALVE	-- ACCUMULATOR PISTON SEAL FAILURE	-- RE-BUILD ACCUMULATOR

NOTE: If any of the above measures are unsuccessful, contact, Hyson Products @ 1-800-876-4976, or call your local sales representative.

Component Torque Requirements;

If it is necessary to replace any components on a Delay System, it is **important** to apply the proper torque to each particular component.

Manifold Items:

COMPONENT TYPE	SIZE OR P/N:	TORQUE VALUE
DRAC 6 CYL. MTG. BOLTS	5/8 - 11 S.H.C.S.	100 - 110 ft/lbs
DRAC 2.5 CYL. MTG. BOLTS	5/8 - 11 S.H.C.S.	100 - 110 ft/lbs
MANIFOLD CHECKS	CXHA-XAV	150 - 160 ft/lbs
PORT PLUGS		
-4 PORT PLUGS	NF-771-4	11 ft/lbs
-5 PORT PLUGS	NF-771-5	15 ft/lbs
-8 PORT PLUGS	NF-771-8	46 ft/lbs
-10 PORT PLUGS	NF-771-10	75 ft/lbs
-12 PORT PLUGS	NF-771-12	85 ft/lbs
-14 PORT PLUGS	NF-771-14	130 ft/lbs
-16 PORT PLUGS	NF-771-16	135 ft/lbs
-20 PORT PLUGS	NF-771-20	225 ft/lbs
-24 PORT PLUGS	NF-771-24	250 ft/lbs
-32 PORT PLUGS	NF-771-32	325ft/lbs
m82 PORT PLUGS	NF-771-m82	800 ft/lbs
m100 PORT PLUGS	NF-771-m100	800ft/lbs
SIGHT PLUG	AA-6160	85 ft/lbs

Delay Module:

COMPONENT TYPE	SIZE OR P/N:	TORQUE VALUE
DRS2 (SOLENOID VALVE)	DRAC-VLV-2WNO	30 - 35 ft/lbs
SPD2 (FLOW CONTROL)	FXFA-XAV-XXX	350-360 ft/lbs
-10 PORT PLUGS	NF-771-10	70 - 75 ft/lbs
-12 PORT PLUGS	NF-771-12	85 - 90 ft/lbs
MODULE MTG. BOLTS	1/2 - 13	45 - 50 ft/lbs

System Start-up - Quick Reference

If the Delay Manifold System is already charged with Nitrogen;

1. Verify System Electrical lines are hooked up to the press controls.
2. Verify System Timing is correct (ref.: manual section 3).

If the Delay Manifold is not already charged with Nitrogen;

1. **Slowly** begin charging **Nitrogen** Reservoir in the Delay Manifold. Once the System pressure reaches 200 - 250 psi, increase the fill rate. Charge the System to the appropriate charge pressure (Note: maximum System pressure not to exceed 1500 psi **die closed**) (ref.: manual section 4).
2. **Slowly** charge the **Accumulator** in the Delay Manifold. Charge the System to the appropriate charge pressure. (ref.: manual section 4).
3. Verify System Electrical lines are hooked up to the press controls.
4. Verify System Timing is correct (ref.: manual section 3).