

# Dyne-A-Cam™ Series

## NITRO-CAM™ MANUAL

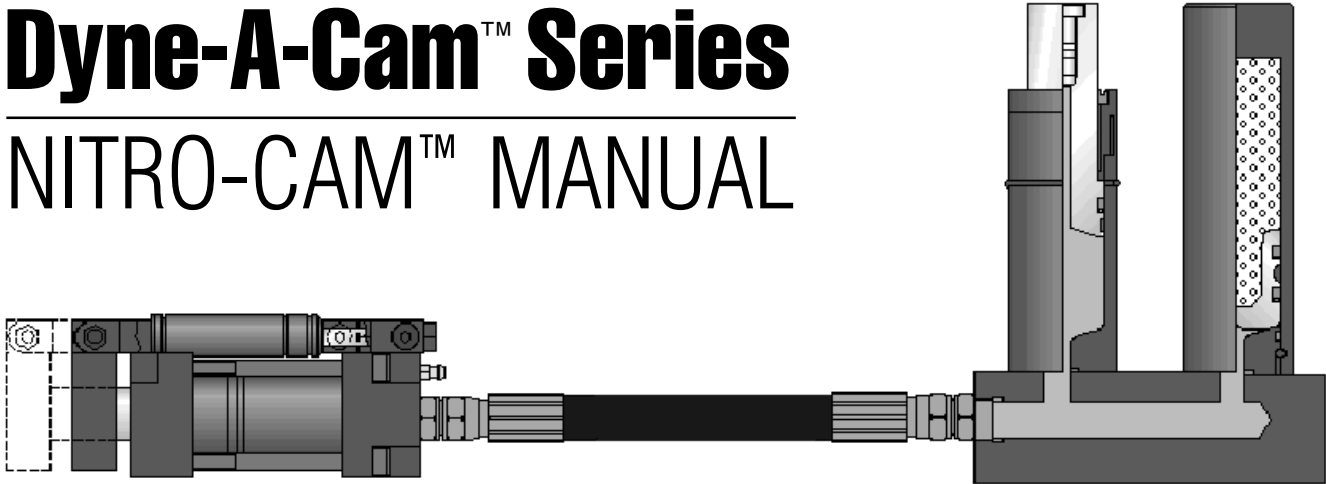

**Hyson™ Products**  
Associated Spring 

BASIC PRINCIPLES, DYNAMIC SOLUTIONS™



NCM0100100

# Dyne-A-Cam™ Series

---

## NITRO-CAM™ MANUAL

## Table of Contents

	Page
General Description .....	2
Features and Benefits .....	3
How the System Works .....	4
Component Selection .....	5-11
System Examples .....	12
Installation .....	13
Filling of Oil and Gas .....	14-16
Replenishing the gas in the accumulator .....	14
Filling and bleeding with oil .....	15-16
Maintenance .....	17-21
Recommended Operating Conditions .....	17
Troubleshooting .....	17
Replacement of the power cylinder .....	18
Replacement of the accumulator .....	19
Replacement of the force cylinder .....	20
Replacement of the return gas spring .....	21
Safety Guidelines .....	22
Dimensions .....	23

## Power Unit (HCPU)

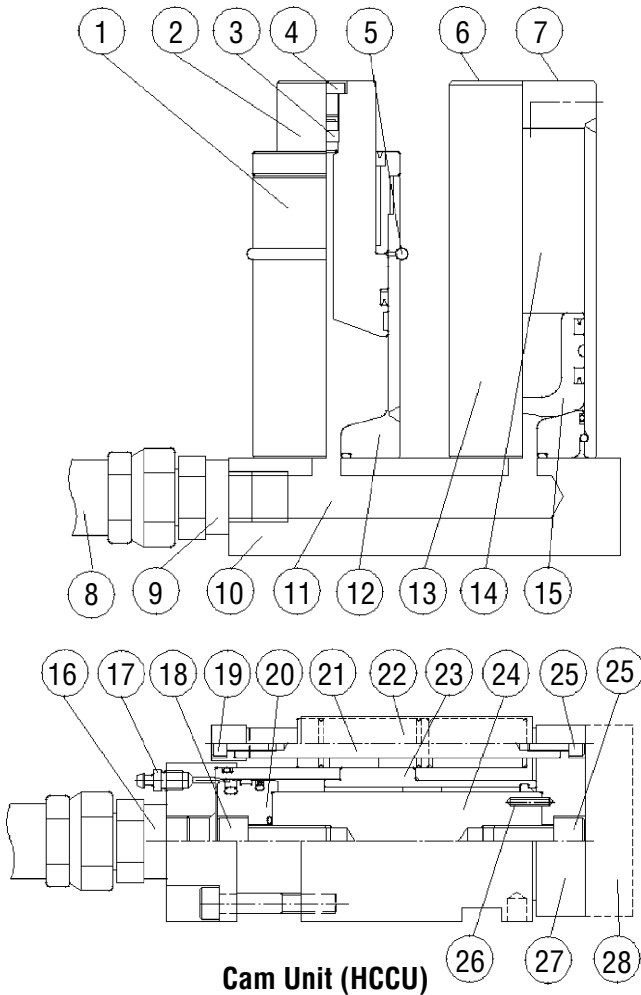

**Figure A**

- |                              |                                       |
|------------------------------|---------------------------------------|
| 1 = Power cylinder           | 15 = Accumulator piston               |
| 2 = Power cylinder rod       | 16 = Adapter                          |
| 3 = Oil check valve          | 17 = Bleed nipple                     |
| 4 = Port plug                | 18 = Oil                              |
| 5 = Breather O-ring          | 19 = Bolts                            |
| 6 = Rupture disk             | 20 = Piston                           |
| 7 = Port plug                | 21 = Anti-rotation rods               |
| 8 = Hose                     | 22 = Return gas springs               |
| 9 = Adapter                  | 23 = Guide                            |
| 10 = Baseplate               | 24 = Piston rod                       |
| 11 = Oil                     | 25 = Adapter plate bolts              |
| 12 = Power cylinder body     | 26 = Anti-rotation pin                |
| 13 = Accumulator             | 27 = Adapter plate                    |
| 14 = Nitrogen N <sub>2</sub> | 28 = Adapter plate, extended position |

The Dyne-A-Cam™ Nitro-Cam System offers a wide range of versatility in the design and processing of dies requiring cam pierce operations.

The system consists of the Nitro-Cam cam unit (HCCU) and the Nitro-Cam power unit (HCPU). An adapter plate is mounted on the front of the cam, and single or multiple punches can be attached. The power unit, which contains the accumulator and power cylinder, is connected to the cam by a high-pressure hose. A KISS or actuator block connected to the ram of the press actuates the power cylinder and eliminates the need for bulky mechanical drivers. As the press begins to compress the power cylinder, the oil is forced out of the cylinder, through the hose, and into the cam unit. This oil pressure drives the punch forward and pierces the material.

The cam unit (*fig A*) can be positioned anywhere in the die, at any angle. The power unit is positioned remotely (clear of any transfer or loading equipment).

The cam unit is available in three standard models: 1.5, 4 and 9 tons, with stroke lengths up to 3.90". Both piercing and return forces are fully adjustable.

For piercing applications it is possible to connect multiple cams (up to three) to a single power unit.

**Note: If timing is critical, each cam unit must be connected to its own power unit.**

### Conversion Information:

1" = 25.4 mm

1 ton = 2000 lbs = 8900 N

**Features**

**Benefits**

- 
- |  |  |
|--|--|
| <ul style="list-style-type: none"><li>• The power unit can be mounted lower than the cam unit and up to 6 feet away.</li></ul> | <ul style="list-style-type: none"><li>• Increases mounting options; simplifies installation and retrofits.</li></ul> |
|--|--|
- 
- |   |   |
|---|---|
| <ul style="list-style-type: none"><li>• The pierce can be mounted off center.</li></ul> | <ul style="list-style-type: none"><li>• Simplifies installation and allows for gang piercing.</li></ul> |
|---|---|
- 
- |   |   |
|---|---|
| <ul style="list-style-type: none"><li>• Maximum pressure is 2610 psi (180 bar).</li></ul> | <ul style="list-style-type: none"><li>• Lower and safer system pressure than competitive units.</li></ul> |
|---|---|
- 
- |  |   |
|--|---|
| <ul style="list-style-type: none"><li>• Controllable piercing force.</li></ul> | <ul style="list-style-type: none"><li>• Piercing force can be easily adjusted by adjusting gas pressure in the accumulator.</li></ul> |
|--|---|
- 
- |   |  |
|---|--|
| <ul style="list-style-type: none"><li>• Easily accessible nitrogen fill port on accumulator. Return gas spring can be quickly accessed and recharged/rebuilt.</li></ul> | <ul style="list-style-type: none"><li>• Easy to service.</li></ul> |
|---|--|
- 
- |  |   |
|--|---|
| <ul style="list-style-type: none"><li>• High-precision dowel holes and key groove.</li></ul> | <ul style="list-style-type: none"><li>• Allows precise cam mounting and location of pierce.</li></ul> |
|--|---|
- 
- |   |  |
|---|--|
| <ul style="list-style-type: none"><li>• Built-in internal mechanical stop for exact cam stroke.</li></ul> | <ul style="list-style-type: none"><li>• Simplifies installation.</li></ul> |
|---|--|
- 
- |  |  |
|--|--|
| <ul style="list-style-type: none"><li>• Oil flow is routed to the accumulator in the event that the cam is unable to stroke.</li></ul> | <ul style="list-style-type: none"><li>• Prevents over-pressurization of cam.</li></ul> |
|--|--|
- 
- |   |   |
|---|---|
| <ul style="list-style-type: none"><li>• Self-contained gas spring(s) provides the return force.</li></ul> | <ul style="list-style-type: none"><li>• Controllable return force by adjusting nitrogen pressure of spring.</li></ul> |
|---|---|
- 
- |  |   |
|--|---|
| <ul style="list-style-type: none"><li>• Retainer mounting surface is compatible with standard retainers and punches.</li></ul> | <ul style="list-style-type: none"><li>• Well-suited for retrofits and design modifications.</li></ul> |
|--|---|
- 
- |  |   |
|--|---|
| <ul style="list-style-type: none"><li>• One power unit can drive up to 3 cams.</li></ul> | <ul style="list-style-type: none"><li>• Lower initial investment and an increase in installation options.</li></ul> |
|--|---|
- 
- |   |   |
|---|---|
| <ul style="list-style-type: none"><li>• The cam can be mounted at any angle in the die.</li></ul> | <ul style="list-style-type: none"><li>• Increased installation possibilities.</li></ul> |
|---|---|
- 
- Hyson™ Products**  
Associated Spring 
- Page 3

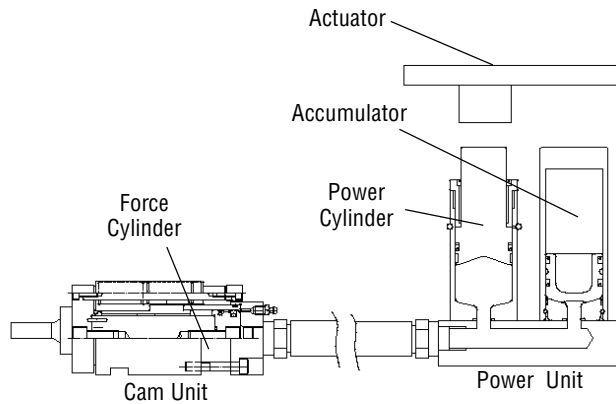

**Die Open (I)**

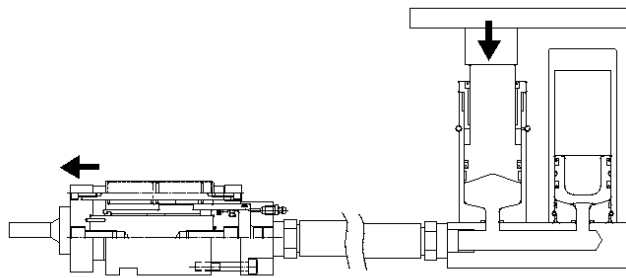

**Work Travel (II)**

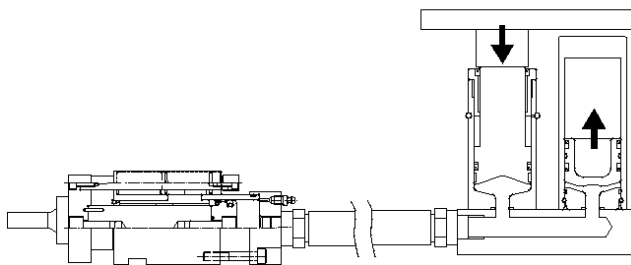

**BDC (III)**

**Figure B**

In the die open position (position I, *fig B*), the power cylinder (in the power unit) and accumulator are in the fully extended position. The force cylinder (in the cam unit) is in the fully retracted position. The oil pressure in the system is zero.

Upon contact with the power cylinder from the ram (using an actuator), the force cylinder begins to extend (work travel, position II).

At bottom dead center (bdc), when the cam has reached its mechanical stop (position III), any remaining fluid (from power cylinder) will be routed into the accumulator.

The nitrogen pressure in the accumulator is responsible for maintaining the proper cam system force during the work travel. The return gas spring(s) in the cam unit is responsible for the retraction force required of the cam (10-20% of the specified maximum force of the cam system).

**Note: The power cylinder stroke is designed to be 0.39 in/10 mm longer than the cam unit total stroke. The system must be designed to use the full stroke of the power cylinder. The additional travel is needed to compensate for any compressibility of fluid, trapped gas, or hose expansion during the stroke. Any unused fluid from the power cylinder will be routed into the accumulator.**

Once past bottom dead center (bdc), the power cylinder is allowed to extend and the return gas spring(s) retracts the cam.

These step-by-step instructions aid in selecting the components needed to make up a custom cam system. The components include the cam unit(s), the power unit, hose, and hose fittings.

**Multiple Cam Systems**

In the Dyne-A-Cam™ Nitro-Cam System, it is possible to operate up to three cams from a single power unit. When running multiple cams from one power unit, the timing of the cams varies due to differences in friction, hose expansion and gas pressure variation. **For applications where timing is critical, each cam unit should have its own power unit.**

**Note:** This selection guide addresses only multiple cam systems in which all cams in the system are the same tonnage and stroke. When combining different models and stroke lengths, it is hard to predict the timing and stroke of the cams.

**Cam Unit Selection**

**Step 1: Calculate the required piercing force in tons per unit.** Take into account tool wear, variation in material thickness, and tensile strength or loss due to stripping force.

Required force (A):  tons

*Ex: The required piercing force to punch a hole in a panel was calculated to be 2.5 tons.*

**Step 2: Select the cam unit size based on the required force (A).** The force ranges per model are tabulated below.

 **Do not undersize the cam model. If the required force is close to the maximum unit force, choose the next larger size cam.**

Required Force Tons (KN)	Cam Unit Size
0 to 1.5 (0-15)	015
1.5 to 4 (15-40)	040
4 to 9 (40-90)	090

Cam unit size (B):

*Ex: For a required piercing force of 2.5 tons, the correct cam size is 040.*

**Step 3: Calculate the required work stroke for the piercing operation.** This is the distance the punch must travel to do the required task.

Required work stroke (C):  in/mm

*Ex: Required work stroke for the piercing tool is 1.5"/38 mm including clearance and over-stroke.*

# Nitro-Cam System

## Component Selection Guide

(continued)

**Step 4: Select the cam unit stroke length.** Round up the required work stroke (C) to the closest cam unit stroke. The cam stroke lengths are tabulated below. **Note: The entire cam stroke must be used. Install the cam unit in the tool so that the entire stroke is used.**

Required Work Stroke (in/mm)	Maximum Unit Stroke (in/mm)	Unit Stroke (mm)
0-0.94 in 0-24 mm	.94 in 24 mm	24
0.94-1.92 in 24-49 mm	1.92 in 49 mm	49
1.92-3.89 in 49-99 mm	3.89 in 99 mm	99*

\* Only available on the 040 and 090 cam sizes.

Unit stroke (D):

mm

*Ex: For a required work stroke of 1.5"/38 mm, the correct cam unit stroke length is 1.92"/49 mm. Therefore the 49 stroke length model is chosen. The cam unit must be positioned in the tool so that the entire 1.92"/49 mm of stroke is used to perform the pierce.*

**Step 5: Determine the correct cam unit part number.**

The part number is based on the the unit size (B) and the stroke length (D).

Unit part number (E):

HCCU-
X

*Ex: The part number is HCCU-040X49.*

**Power Unit Selection**

**Step 6: Select the power unit.** The possible power unit and cam unit combinations are shown in the chart below. Based on the shut height and spatial limitations in the tool, and the combinations illustrated below, select the power unit for the cam units selected (E). Remember a maximum of three cams can be connected to a single power unit.

**Note:** The table below tabulates the maximum recommended power cylinder stroke lengths when running the selected cam unit(s). The maximum recommended power cylinder stroke should be used at all times. When running smaller cam models on larger model power units (for example HCCU-015X49 connected to HCPU-040X35), the maximum recommended stroke of the power unit is less than the capability of the power unit. If the working travel of the power cylinder exceeds the recommended values, the life of the system will be affected.

**Maximum Recommended Power Cylinder Stroke in Inches**

Cam Part Number	#	HCPU-015X35	HCPU-015X60	HCPU-040X35	HCPU-040X60	HCPU-040X110	HCPU-090X35	HCPU-090X60	HCPU-090X110
015X24	1	1.338	—	—	—	—	—	—	—
	2	—	2.283	1.156	—	—	—	—	—
	3	—	—	—	1.536	—	0.847	—	—
015X49	1	—	2.323	1.171	—	—	—	—	—
	2	—	—	—	1.949	—	1.011	—	—
	3	—	—	—	—	2.727	1.320	—	—
040X24	1	—	—	1.338	—	—	—	—	—
	2	—	—	—	2.283	—	1.144	—	—
	3	—	—	—	—	3.228	—	1.519	—
040X49	1	—	—	—	2.323	—	1.159	—	—
	2	—	—	—	—	4.252	—	1.925	—
	3	—	—	—	—	—	—	—	2.691
040X99	1	—	—	—	—	4.291	—	1.941	—
	2	—	—	—	—	—	—	—	3.488
	3	—	—	—	—	—	—	—	—
090X24	1	—	—	—	—	2.774	1.339	—	—
	2	—	—	—	—	—	—	2.283	—
	3	—	—	—	—	—	—	—	3.228
090X49	1	—	—	—	—	—	—	2.323	—
	2	—	—	—	—	—	—	—	4.252
	3	—	—	—	—	—	—	—	—
090X99	1	—	—	—	—	—	—	—	4.291
	2	—	—	—	—	—	—	—	—
	3	—	—	—	—	—	—	—	—

All tabulated stroke lengths include 0.39 in/10 mm of overtravel required.  
Tabulated stroke lengths are nominal. Actual stroke lengths should be +/- .010.

Power unit part number (F):

HCPU-      X
--------------

*Ex: For the HCCU-040X49 selected in step 6, there are two power unit options. Option 1 is to select HCPU-040X60 with a working stroke of 2.323 in. Option 2 is to select HCPU-090X35 with a maximum working stroke of 1.159 in. For this example, we will select HCPU-040X60.*

# Nitro-Cam System Component Selection Guide

(continued)

**Step 7: Determine the charge pressure of the accumulator.** The accumulator pressure controls the piercing force. Based on the graphs below and the piercing force calculated (A), determine the accumulator charge pressure.

Accumulator charge pressure (G):

psi/bar

*Ex: For a required piercing force of 2.5 tons (5,000 lbs) and cam model HCCU-040, the minimum recommended charge pressure is 1350 psi. Taking into account variation in material thickness and tool wear, we will select a pressure approximately 20% greater than the minimum value (1620 psi).*

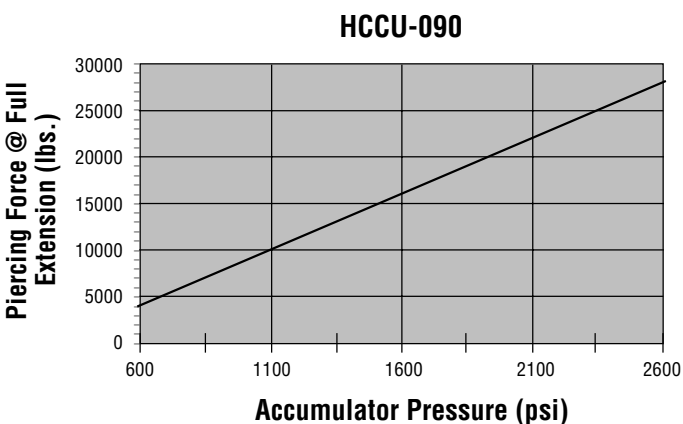
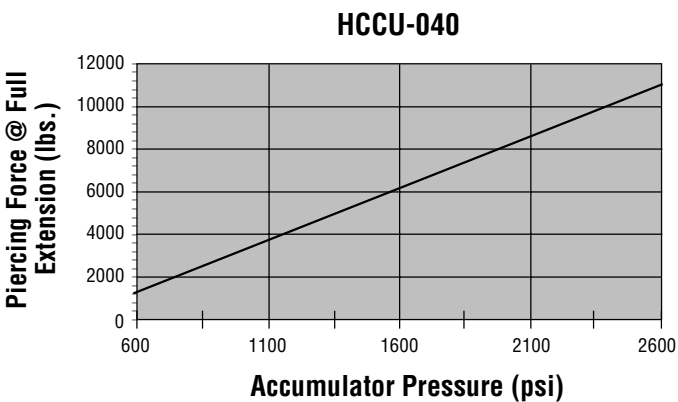
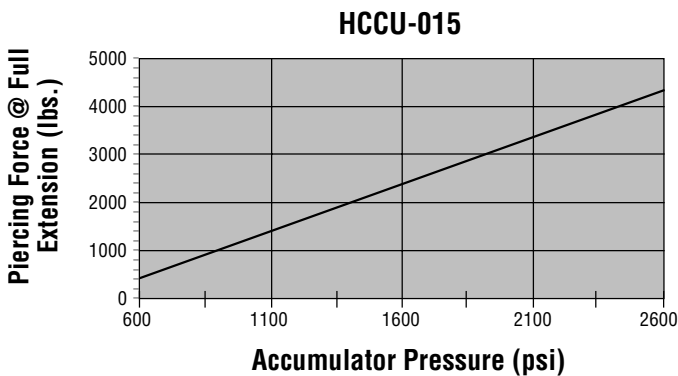

**Hose & Fittings Selection**

The hose assembly(ies), cam unit adapter(s), power unit adapter and hose connectors need to be selected. Improper hose and hose fitting selection can result in premature system failure.

**Step 8: Determine the hose assembly(ies) part number(s).** The size of hose is a function of the power unit. Based on the power unit chosen in (F) and the system layout, determine the hose assembly(ies) required.

**Hose, Straight-Straight Swivel**

Power Unit Part No.	Hose Assembly Part Number
HCPU-015	HCHA-015-180-XX
HCPU-040	HCHA-040-180-XX
HCPU-090	HCHA-090-180-XX

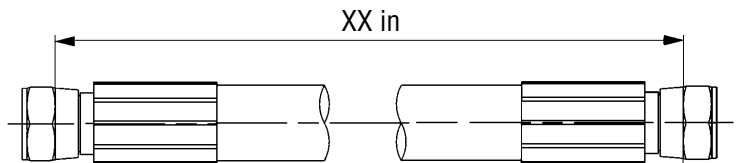

**Hose, Straight-45° Swivel**

Power Unit Part No.	Hose Assembly Part Number
HCPU-015	HCHA-015-45-XX
HCPU-040	HCHA-040-45-XX
HCPU-090	HCHA-090-45-XX

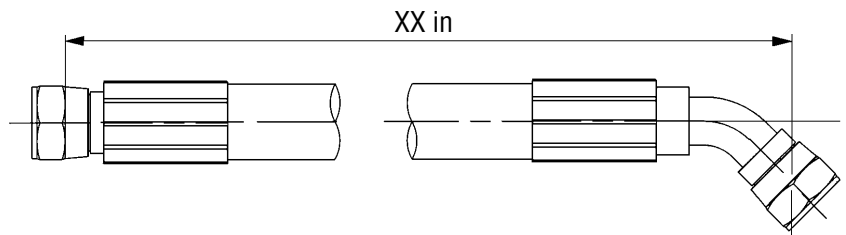

**Hose, Straight-90° Swivel**

Power Unit Part No.	Hose Assembly Part Number
HCPU-015	HCHA-015-90-XX
HCPU-040	HCHA-040-90-XX
HCPU-090	HCHA-090-90-XX

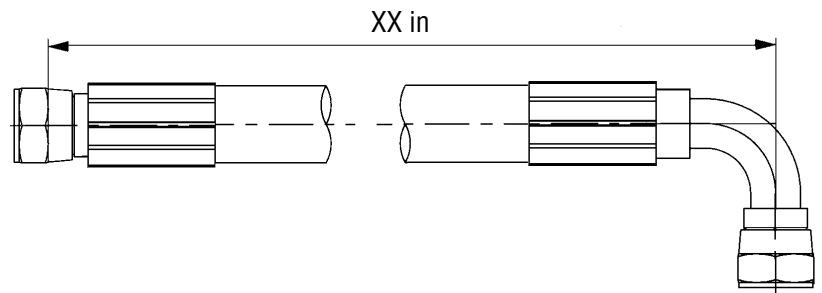





Hose assembly part number (H):

*Ex: For this example, the distance between the power unit and cam ports is 5 feet (60 inches). We selected HCHA-040-180-60.*

# Nitro-Cam System Component Selection Guide

(continued)

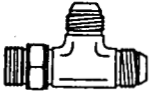
**Step 9: Select the necessary cam unit adapter(s).** The particular size of adapter(s) is determined by the appropriate power and cam units. Based on the cam(s), power unit, and system geometry, select the cam adapter(s) required.

<b>Straight end fitting</b>		Cam Unit	HCPU-015	HCPU-040	HCPU-090
	HCCU-015	8-8F40MXS	12-8F40MXS	—	
	HCCU-040	—	12F40MXS	16-12F40MXS	
	HCCU-090	—	12F40MXS	16-12F40MXS	
	<hr/>				
<b>90° Elbow</b>		Cam Unit	HCPU-015	HCPU-040	HCPU-090
	HCCU-015	8-8C40MXS	12-8C40MXS	—	
	HCCU-040	—	12C40MXS	16-12C40MXS	
	HCCU-090	—	12C40MXS	16-12C40MXS	
	<hr/>				
<b>Run Tee (for multiple cams powered by a single power unit)</b>		Cam Unit	HCPU-015	HCPU-040	HCPU-090
	HCCU-015	8R40MXS	12-8R40MXS	16-8R40MXS	
	HCCU-040	—	12R40MXS	16-12R40MXS	
	HCCU-090	—	12R40MXS	16-12R40MXS	
	<hr/>				
<b>Branch Tee (for multiple cams powered by a single power unit)</b>		Cam Unit	HCPU-015	HCPU-040	HCPU-090
	HCCU-015	8S40MXS	12-8S40MXS	16-8S40MXS	
	HCCU-040	—	12S40MXS	16-12S40MXS	
	HCCU-090	—	12S40MXS	16-12S40MXS	
	<hr/>				

Cam unit adapter part number (I):

*Ex: For this example, we will use a straight adapter. For cam part number HCCU-040X49 and power unit HCPU-040X60, the cam adapter part number is 12F40MXS.*

(continued)

**Step 10: Select the power unit adapter.** Based on the power unit (H) and system geometry, select the appropriate adapter.

**Straight end fitting**



Power unit	Adapter part no.
HCPU-015	8-8F40MXS
HCPU-040	12F40MXS
HCPU-090	16-12F40MXS

**90° Elbow**



Power unit	Adapter part no.
HCPU-015	8-8C40MXS
HCPU-040	12C40MXS
HCPU-090	16-12C40MXS

**Run Tee (for multiple cams powered by a single power unit)**



Power unit	Adapter part no.
HCPU-015	8R40MXS
HCPU-040	12R40MXS
HCPU-090	16-12R40MXS

**Branch Tee (for multiple cams powered by a single power unit)**

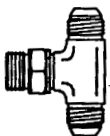

Power unit	Adapter part no.
HCPU-015	8S40MXS
HCPU-040	12S40MXS
HCPU-090	16-12S40MXS

Power unit adapter part number (J):

*Ex: For this example, we will use a straight adapter. For power unit HCPU-040X60, the adapter part number is 12F40MXS.*

**Step 11: Select the hose connectors.** For multiple hose segments only. Based on the power unit model and the routing of hoses during installation, select the connectors.

	HCPU-015	HCPU-040	HCPU-090
<b>Elbow</b>	8-ETXS	12-ETXS	16-ETXS



<b>Union</b>	8-HTXS	12-HTXS	16-HTXS
--------------	--------	---------	---------



<b>Union Tee</b>	8-JTXS	12-JTXS	16-JTXS
------------------	--------	---------	---------



<b>Union Cross</b>	8-KTXS	12-KTXS	16-KTXS
--------------------	--------	---------	---------

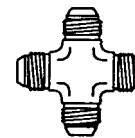

Hose connectors part number (K):

*Ex: For this example, only one hose segment was used; therefore no hose connectors are necessary.*

**Step 12: Selection process complete.** See working example, page 12.

**Working Example**

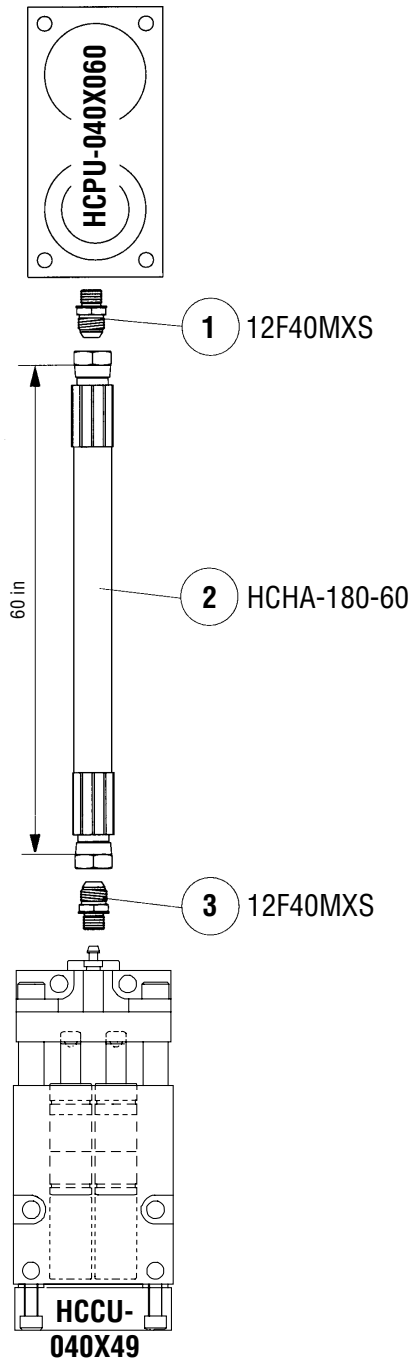

**Multiple Cam System Example**

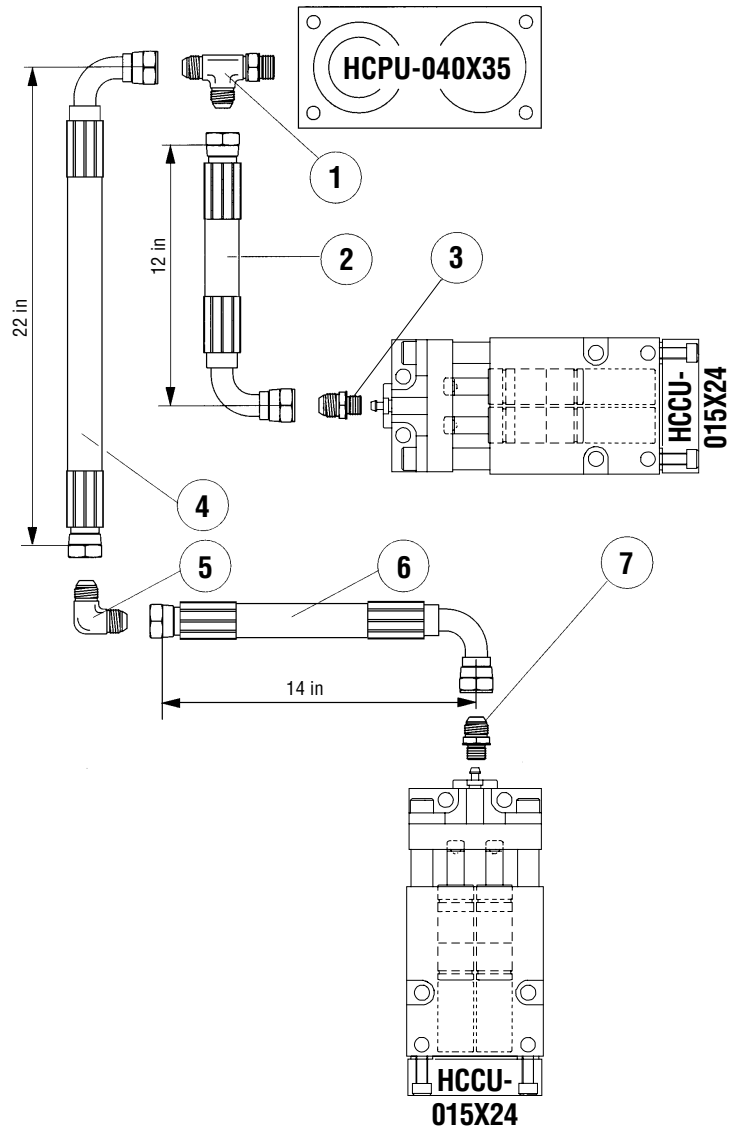

Position	Order Number
1	12R40MX
2	HCHA-90-12
3	12-8F40MXS
4	HCHA-90-22
5	12-ETXS
6	HCHA-90-14
7	12-8F40MXS

**Punch and/or Retainer Installation**

The adapter plate can be drilled and tapped easily to accommodate standard punch and/or punch retainers.

**⚠ It is recommended that the punch or resultant force (for multiple pierce applications) is located in the center of the piston rod (C-C, fig C); however, it is possible to locate the punch or the resultant force within the shaded area (fig C).**

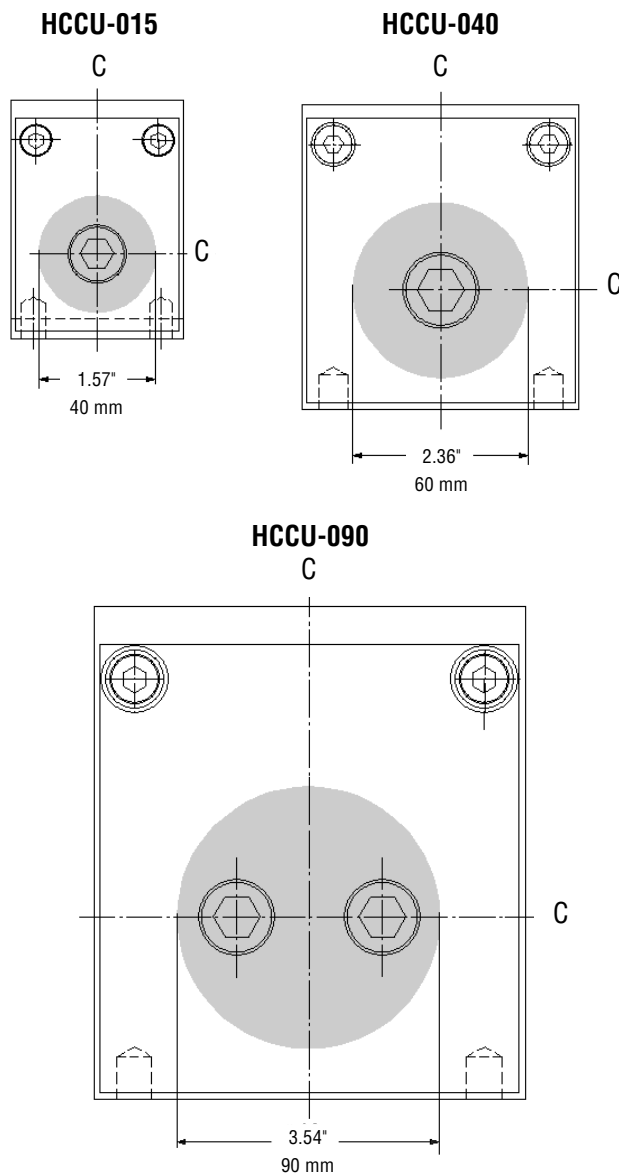

**Figure C**

**Cam Unit Installation into the Tool**

To install the cam into the tool, four mounting holes, two dowel holes and a key groove are provided. In order to access all of the mounting holes, the cam unit's anti-rotation rods must be partially removed. Using an Allen key, unscrew the two bolts located on the punch retainer surface that are attached to the anti-rotation rods. Once these screws are removed, the anti-rotation rods can be slid out of the way and the mounting bolt holes become accessible. (See Figure A.)

When the cam unit is fastened to the tool, reinsert the anti-rotation rods and attach the screws. See Table 1 for torque specifications.

**Table 1: Bolt Specifications**

Bolt Size	Allen Key (mm)	Torque	
		(in*lb)	(Nm)
M6	5	133	15
M8	6	354	40
M10	8	664	75
M12	10	1195	135
M16	14	2921	330
M20	17	3717	420

**Power Unit Installation in the Tool**

The power unit can be mounted at any position up to 6 feet (2 meters) from the cam. (The total length of hose in the system must not exceed 6 feet.) Four mounting holes are located in the base of the power unit for mounting in the tool.

The actuator should be contacting the power cylinder so that no side loading is occurring.

**⚠ The height of the accumulator is greater than the compressed height of the power cylinder. Make sure you account for the accumulator height in your installation. Failure to align the power unit in the die correctly could result in damage to the accumulator and potential personal injury.**

## Replenishing the Gas in the Accumulator

### Equipment needed:

- Replenishing armature
- 5 mm Allen key

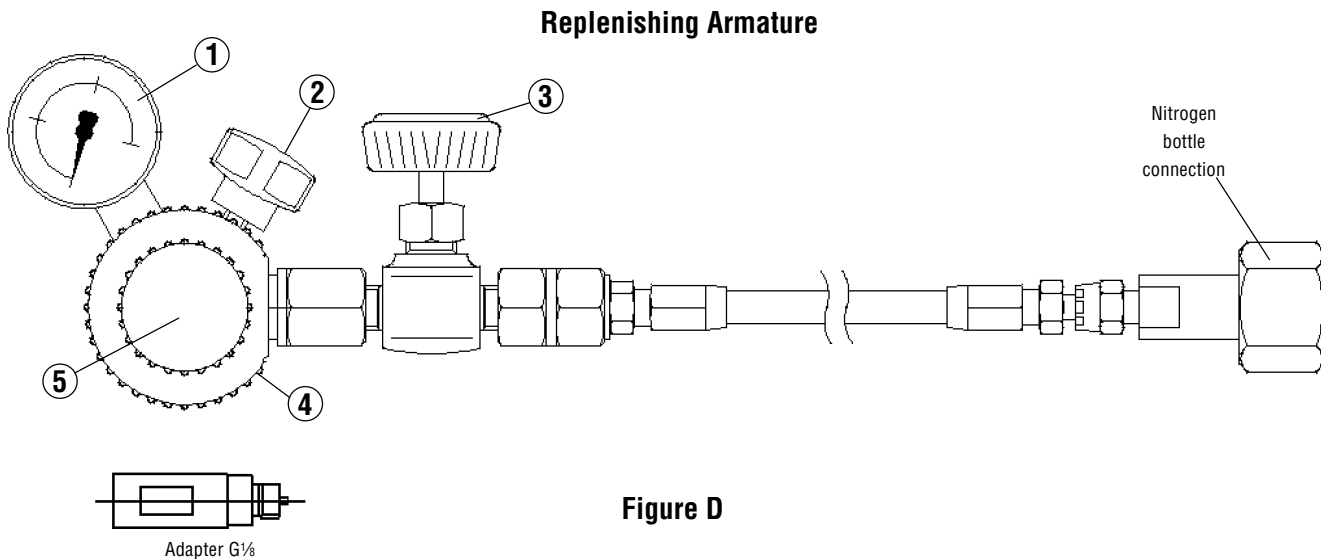

1. Connect the replenishing armature to a nitrogen bottle with regulator.
2. Be sure release pin on armature is inside the thread, turn knob (pos 5, *fig D*) counter-clockwise. Connect replenishing armature with adapter (*fig D*) to the charging port of the accumulator (pos 7, *fig A*, see pg 2) by turning the knob (pos 4, *fig D*) clockwise.
3. Open the stop valve (pos 3, *fig D*) slowly on the armature. Charge nitrogen slowly until the gauge (pos 1, *fig D*) reads 363 psi (25 bar).
4. Refer to “Filling and Bleeding with Oil,” page 15, prior to proceeding to step 5.
5. After filling and bleeding the system with oil, charge the accumulator to the desired pressure.
6. Empty the gas inside the armature and hose by closing the valve on the nitrogen bottle. Open the bleed valve by turning the knob (pos 2, *fig D*) counter-clockwise. Make sure that the stop valve (pos 3, *fig D*) on the armature is open.

**⚠ The nitrogen pressure in the accumulator may not exceed 2610 psi (180 bar).**

**Filling and Bleeding with Oil**

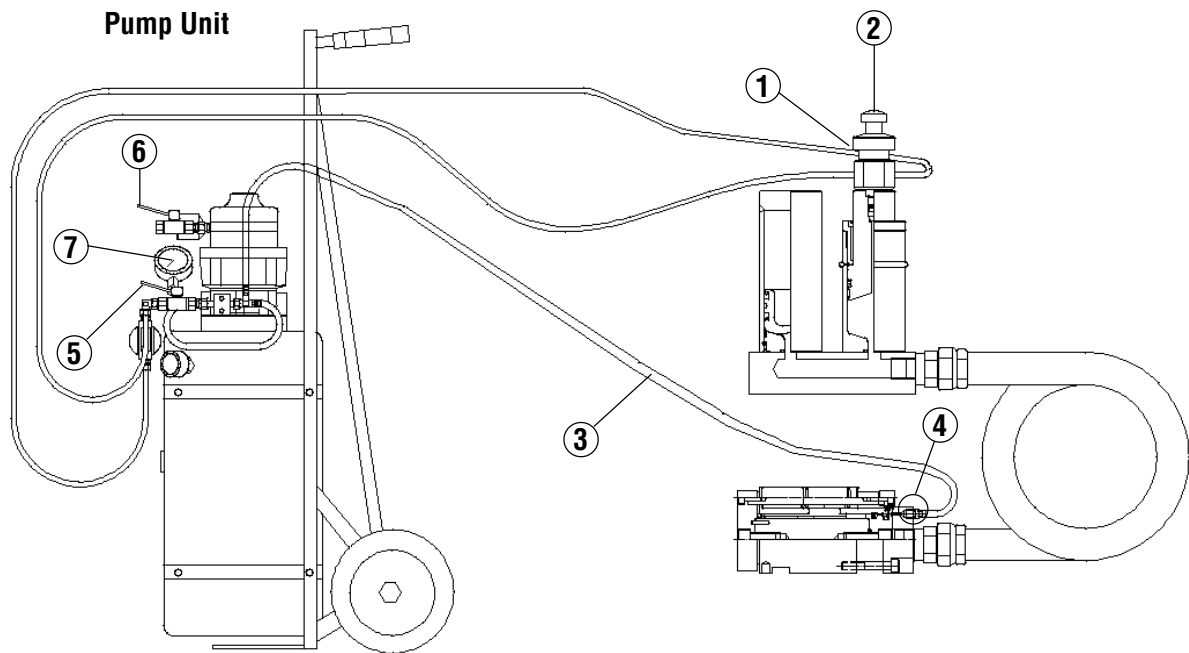

**Figure E**

**Equipment needed:**

- Cam pump unit
- Oil filling/bleeding assembly
- 6 mm Allen-type socket & ratchet
- 11 mm box/open end wrench
- 5 gal (18 liters) of Shell Tellus T32 oil or equivalent

**Compressed air specifications:** pressure between 72-100 psi (5-7 bar). Moisture trap, filter and automatic air line lubricator must be installed in the air line to feed the air motor of the pump.

1. Charge the accumulator of the power unit slowly with nitrogen (N<sub>2</sub>) to a pressure of 363 psi (25 bar). (See “Replenishing the Gas in the Accumulator,” page 14).
2. Install the oil filling/bleeding armature on the top of the power cylinder by turning the large mounting

knob (pos 1, *fig E*) clockwise until finger tight.

**Do not over-tighten.** Open the valve at the top of the power cylinder by carefully turning the small knob (pos 2, *fig E*) clockwise.

3. Connect a transparent hose (pos 3, *fig E*) between the bleed nipple (pos 4, *fig E*) on the cam unit and the pump unit.
4. Open the bleed nipple (pos 4, *fig E*) on the cam unit using an 11 mm box/open end wrench (approx. ¼ turn). Close the valve (pos 5, *fig E*) on the pump unit. Connect the compressed air (see compressed air specifications) to the valve (pos 6, *fig E*). The size of the thread in the valve is G ¼. Open the valve (pos 6, *fig E*) and pump oil through the system until the oil is free from air bubbles. Close the bleed nipple (pos 4, *fig E*) on the cam unit. **Do not over-tighten.**

## Filling and Bleeding with Oil

(continued)

5. Pump oil until the oil pressure is 725 psi (50 bar), as read from the gauge (pos 7, *fig E*). **Do not exceed 725 psi (50 bar). Pressures in excess of 725 psi (50 bar) can result in damage to the accumulator.** Open the bleed nipple (pos 4, *fig E*) on the cam unit.

 **Prior to pressurizing with oil, verify that the punch will not damage the die when it is fully extended.**

Repeat this procedure until the oil is free from air bubbles. Close the bleed nipple (pos 4, *fig D*, pg 14) on the cam unit.

6. Pump oil until the oil pressure is 725 psi (50 bar). Open the valve (pos 5, *fig D*, pg 14) on the pump unit. Repeat this procedure until the oil is free from air bubbles.

7. Verify the hose connections are leak free. Release the oil pressure by opening the bleed nipple (pos 4, *fig E*) on the cam unit and remove the transparent hose.

 **Do not proceed until the oil pressure is zero and the cam unit is in the fully retracted position.**

8. Remove the oil filling/bleeding assembly and replace the port plug located at the top of the power cylinder. Tighten with 133-160 in\*lbs (15 - 18 Nm) of torque. Note: The plug has a sealing function and should be securely fastened prior to operating the unit.
9. Charge the accumulator to a maximum of 2610 psi (180 bar) with nitrogen gas. (See “Replenishing the Gas in the Accumulator,” step 5, page 14.)

**Recommended Operating Conditions**

	CC-015		CC-040		CC-090	
Max. Piercing Force	15 kN	1.69 Tons	40 kN	4.5 Tons	90 kN	10.12 Tons
Std. Return Force	2 kN	0.22 Tons	4 kN	0.45 Tons	9 kN	1.01 Tons
Max. Return Force (@ full stroke)	3.3 kN	0.37 Tons	6.7 kN	0.75 Tons	14.7 kN	1.65 Tons
Reduction in Return Force (max.)	-30%		-30%		-30%	
Max. Ram Velocity	0.8 m/s	2.62 ft/s	0.8 m/s	2.62 ft/s	0.8 m/s	2.62 ft/s
Service Duty Cycle	.5 M/yearly		.5 M/yearly		.5 M/yearly	
Rebuild Duty Cycle	1 M		1 M		1 M	
Max. Punch Offset (from bolt center)	20 mm	0.79 in	30 mm	1.18 in	45 mm	1.77 in
Max. Punch Deflection	0.04 mm	0.002 in	0.04 mm	0.002 in	0.04 mm	0.002 in

**Troubleshooting the System**

Problem	Possible causes	Required actions
Cam does not complete the full stroke.	Low gas pressure in the accumulator.	Recharge the accumulator with nitrogen gas. (See “Replenishing the Gas in the Accumulator,” page 14). Note: Maximum charging pressure is 2610 psi (180 bar).
	Power cylinder is not fully stroked.	Adjust the stroke.
	Oil leakage in power cylinder: (A.) Loose port plug. (B.) Damaged seal or ID of the power cylinder.	(A.) Refill the system and replace the port plug. (See “Filling and Bleeding with Oil,” page 15.) (B.) Replace the power cylinder. (See “Replacement of the Power Cylinder,” page 18.)
	Oil leakage in cam unit.	Replace the cam or force cylinder. (See “Replacement of the Force Cylinder,” page 20.)
	Hose or hose connection has been damaged or loosened.	Change the damaged connectors and/or hose assemblies. Refill the system. (See “Filling and Bleeding with Oil,” page 15.)
Cam does not retract.	Low gas pressure in the return gas spring.	Replace the return gas spring. (See “Replacement of the Return Gas Spring,” page 21.)
	Gas leakage from the accumulator into the oil.	Bleed oil. There will be gas bubbles in the oil. (See “Filling and Bleeding with Oil,” page 15.) Replace accumulator. (See “Replacement of Accumulator,” page 19.)
	Cam slide damaged.	Replace complete cam unit.

## Replacement of the Power Cylinder

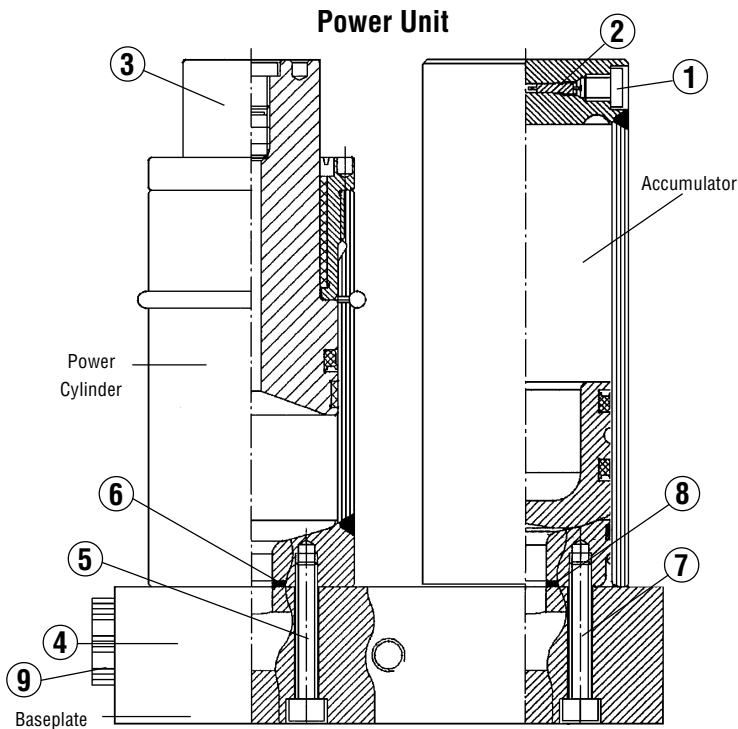

Figure F

### Necessary tools:

- Allen keys - size 5 & 6 mm
- Gas replenishing armature or valve tool for releasing the gas pressure
- Torque wrench
- Allen key for torque wrench (See Table 1, page 13 for specifications.)
- Loc-Tite® 242

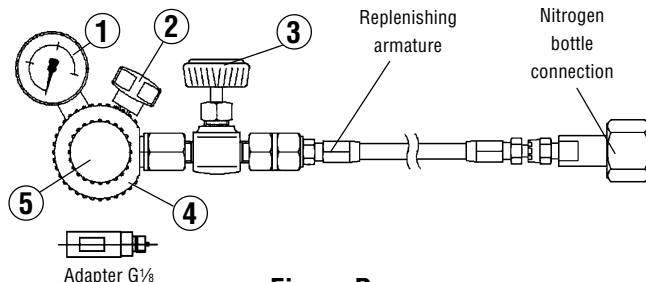

Figure D

### Disassembly

1. Release the gas pressure from the accumulator.  
Unscrew the cover screw (pos 1, fig F). Release the

gas by screwing the threaded end of the valve tool into the filling port until the valve needle (pos 2, fig F) opens.

### Or

Unscrew the cover screw (pos 1, fig F). Release the gas by connecting the replenishing armature to the filling port. Open the valve (pos 2, fig F) by turning the knob (pos 5, fig D) clockwise until the valve is opened. Open the bleed valve by turning the knob (pos 2, fig D) counter-clockwise.

2. Detach the oil hose from the power unit. Plug the end of the hose to prevent the oil from draining onto the tool.
3. Remove the power unit from the tool.
4. Empty the power unit of oil by pressing down the piston (pos 3, fig F) of the power cylinder.
5. Detach the defective power cylinder from the base plate (pos 4, fig F) by removing the fastening bolts (pos 5, fig F).
6. Clean the contact surface on the base plate and inspect for damages.

### Assembly

1. Attach the new power cylinder by using the new bolts supplied with the cylinder. Make sure the O-ring (pos 6, fig F) is in its correct position. Clean the bolts, apply Loc-Tite 242, and tighten according to torque specifications given in Table 1, page 13.
2. Mount the power unit in the tool. (See "Power Unit Installation in the Tool," page 13.)
3. Attach the oil hose (pos 9, fig F).
4. Fill the system. (See "Filling and Bleeding with Oil," page 15.)

### Replacement of the Accumulator

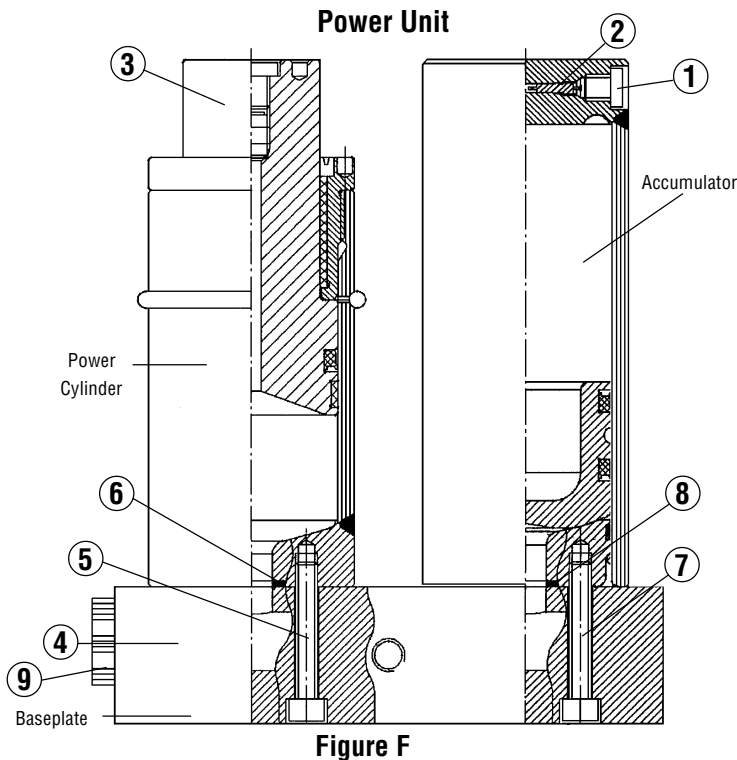

Figure F

#### Necessary tools:

- Allen keys - size 5 & 6 mm
- Gas replenishing armature or valve tool for releasing the gas pressure
- Torque wrench
- Allen key for torque wrench (See Table 1, page 13 for specifications.)
- Loc-Tite® 242

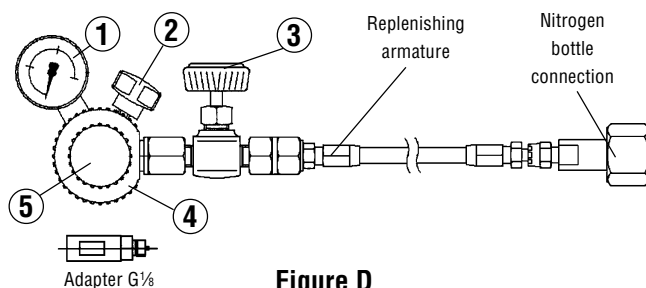

Figure D

#### Disassembly

1. Unscrew the cover screw (pos 1, fig F). Release the gas by screwing the threaded end of the valve tool

into the filling port until the valve needle (pos 2, fig F) opens.

#### Or

Unscrew the cover screw (pos 1, fig F). Release the gas by connecting the replenishing armature to the filling port. Open the valve (pos 2, fig F) by turning the knob (pos 5, fig D) clockwise until the valve is opened. Open the bleed valve by turning the knob (pos 2, fig D) counter-clockwise.

2. Detach the oil hose from the power unit. Plug the end of the hose to prevent the oil from draining onto the tool.
3. Remove the power unit from the tool.
4. Empty the power unit of oil by pressing down the piston (pos 3, fig F) of the power cylinder.
5. Detach the accumulator from the base plate (pos 4, fig F) by removing the fastening bolts (pos 7, fig F).
6. Clean the contact surface on the baseplate and inspect for damages.

#### Assembly

1. Attach the new accumulator by using the bolts provided with the new accumulator. Make sure the O-ring (pos 8, fig F) is in its correct position. Clean the bolts, apply Loc-Tite 242, and tighten according to torque specifications in Table 1, page 13.

**Note:** Upon delivery, the new accumulator is under low pressure. By releasing this pressure, the accumulator tube can be rotated so that the gas inlet port (pos 1, fig F) is located in the preferred position.

2. Mount the power unit in the tool. (See “Power Unit Installation in the Tool,” page 13.)
3. Attach the oil hose (pos 9, fig F).
4. Charge the system with oil and gas as described in the “Filling of Oil and Gas” section, page 14.

## Replacement of the Force Cylinder

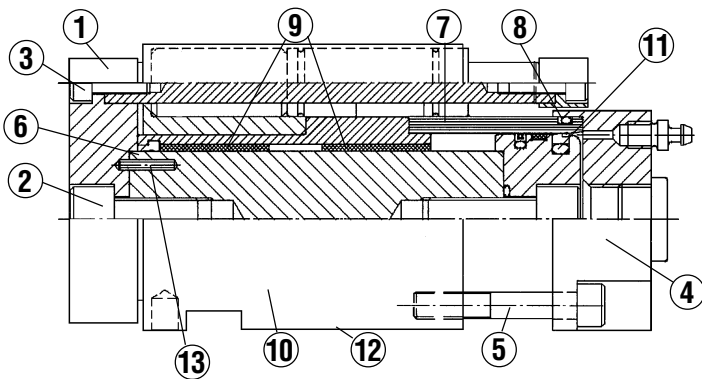

Figure G

### Necessary tools:

- Allen keys:
  - For HCC015: size 5, 6 & 10 mm
  - For HCC040: size 6, 8 & 14 mm
  - For HCC090: size 8, 14 & 17 mm
- Socket wrench: size 11 mm
- Gas replenishing armature or valve tool for releasing the gas pressure
- Torque wrench
- Allen key for torque wrench (See Table 1, page 13 for specifications.)
- Loc-Tite® 242
- Shell Alvania grease G3 or equivalent

### Disassembly

1. Release the gas pressure in the accumulator. (See “Replacement of the Accumulator,” step 1, page 19.)
2. Detach oil hose from cam unit. Plug end of hose to prevent oil from draining on tool.
3. Remove cam unit from tool and place on flat clean surface.
4. Remove adapter plate (pos 1, *fig G*) by removing fastening bolts (pos 2 and 3, *fig G*).
5. Remove cylinder housing (pos 4, *fig G*) by removing fastening bolts (pos 5, *fig G*).
6. Take out piston rod with piston from cam unit by pushing on piston rod (pos 6, *fig G*).

7. Remove sleeve (pos 7, *fig G*) from connection housing (pos 4, *fig G*).

### Assembly

1. Lightly grease the surface of the guide (pos 9, *fig G*) with Shell Alvania G3 or equivalent.
2. Put new sleeve (pos 7, *fig G*) into cam housing (pos 10, *fig G*).
3. Lightly oil the piston seals (pos 11, *fig G*).
4. Place new piston rod with piston (pos 6, *fig G*) into the guide (pos 9, *fig G*). Be careful not to damage the piston seals.
5. Lightly oil the O-ring (pos 8, *fig G*).
6. Place the cylinder housing (pos 4, *fig G*) on sleeve (pos 7, *fig G*).

**⚠ Make sure that the surface underneath the cylinder housing will be parallel with the surface of the cam housing (pos 12, *fig G*).**

7. Apply Loc-Tite 242 to the four new bolts (pos 5, *fig G*) and secure into position. Tighten bolts according to torque specifications shown in Table 1, page 13. Make sure that the surface underneath the cylinder housing will be parallel with the surface of the cam housing (pos 12, *fig G*).
8. Put adapter plate (pos 1, *fig G*) on to piston rod (pos 6, *fig G*) and make sure that the anti-rotation pin (pos 13, *fig G*) is in the proper position.
9. Insert bolts (pos 3, *fig G*) and tighten according to the torque specifications shown in Table 1, page 13.
10. Put bolt (pos 2, *fig G*) in position and tighten according to the torque specifications given in Table 1, page 13.
11. Mount cam unit in the tool. (See “Cam Unit Installation,” page 13.)
12. Attach oil hose.
13. Charge system with oil and gas as described in the “Filling of Oil and Gas” section, page 14.

**Replacement of the Return Gas Spring**

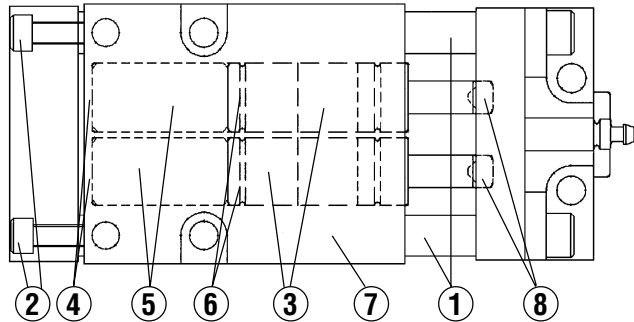

**Figure H**

**Necessary tools:**

- Allen keys: size 5, 6 & 8 mm
- Allen key for torque wrench (See size chart below.)
- Shell Alvania grease G3 or equivalent

**Disassembly**

1. Remove the anti-rotation rods (pos 1, *fig H*) by unscrewing the bolts (pos 2, *fig H*).
2. Remove the return gas springs (pos 3, *fig H*) by pushing from the bottom of the spring(s) (pos 4, *fig H*). If there is a spacer (pos 5, *fig H*), do not remove the spacer from the cam unit.

**Assembly**

1. **For Compact Cam 015 and 040 only:** Lightly oil the O-ring and install on the return gas spring(s) (pos 6, *fig H*).
2. Place the return gas spring(s) (pos 3, *fig H*) in the cam housing (pos 7, *fig H*).
3. Using Shell Alvania grease G3 or equivalent, lightly oil the surface of the guides for the anti-rotation rods (pos 1, *fig H*).
4. Place the anti-rotation rods (pos 1, *fig H*) in the cam housing (pos 7, *fig H*).  
**For Cam 015 & 040 only:** Make sure that the center location pins (pos 8, *fig H*) are in the correct position.
5. Place the bolts (pos 2, *fig H*) and tighten according to Table 1, below.

**Table 1: Bolt Specifications**

Bolt Size	Allen Key (mm)	Torque	
		(in*lb)	(Nm)
M6	5	133	15
M8	6	354	40
M10	8	664	75
M12	10	1195	135
M16	14	2921	330
M20	17	3717	420

 **This symbol indicates WARNING. Personal injury and/or damage to property can result if the instructions are not followed carefully.**

- It is important to maintain a clean working environment whenever working with the Nitro-Cam System. Contamination can dramatically affect the product's service life.
- The height of the accumulator is greater than the compressed height of the power cylinder. Make sure you account for the accumulator height in your installation. Failure to align the power unit in the die correctly could result in damage to the accumulator and potential personal injury.
- Read the manual completely prior to installing or servicing your Dyne-A-Cam™ Nitro-Cam System.
- Do not modify the cam or power unit (with exception of the adapter plate on the cam unit which is designed to be drilled and tapped to accommodate punch retainers).
- When replenishing gas in the accumulator or return spring, use only nitrogen gas (N<sub>2</sub>). Using other types of gas can result in serious personal injury.
- Never fill the accumulator or return spring with more pressure than is permitted. The maximum charge pressure of the accumulator is 2610 psi (180 bar). The maximum charge pressure of the return spring(s) in the HCCU-015 and HCCU-040 model is 2610 psi (180 bar). The maximum charge pressure of the return spring(s) in the HCCU-090 is 2175 psi (150 bar).
- Refer to the gas spring service instructions manual prior to servicing the return gas spring.
- When filling and bleeding the system with oil, never exceed 725 psi (50 bar).
- Make sure both the nitrogen pressure in the accumulator and the oil pressure in the system are zero prior to servicing the system.

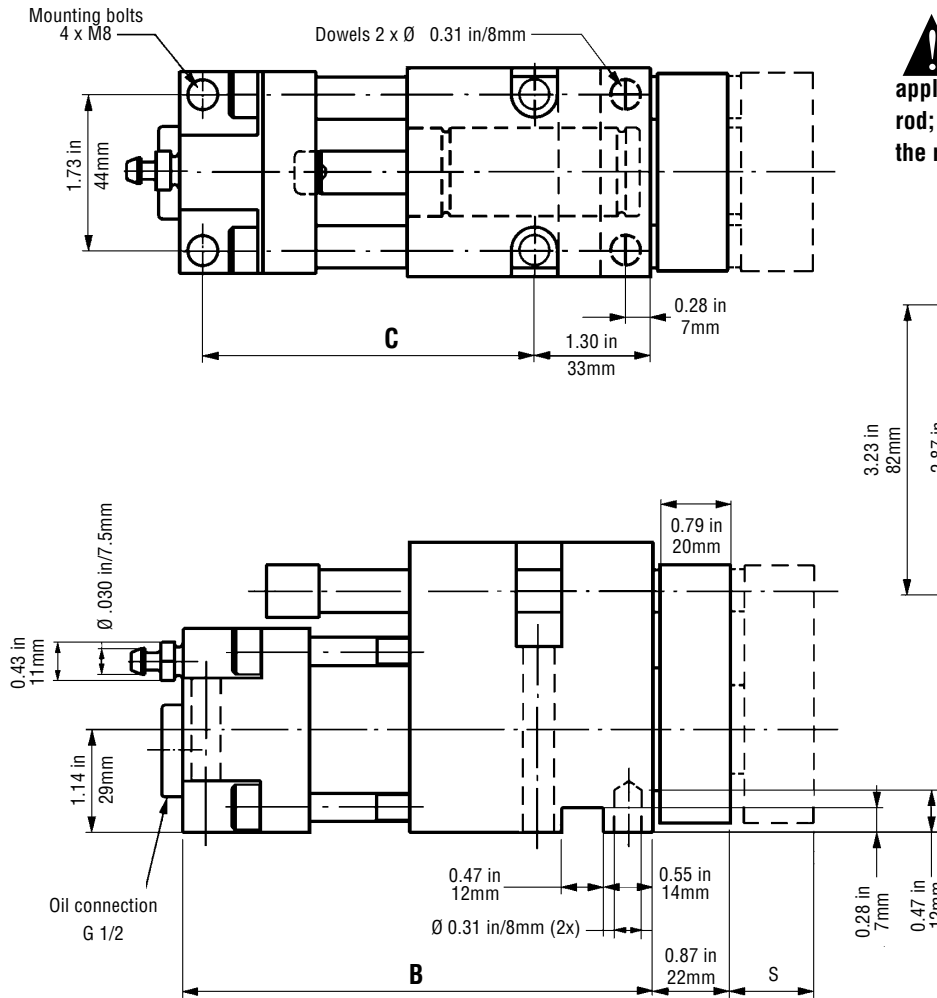

**!** It is recommended that the punch or resultant force (for multiple pierce applications) is located in the center of the piston rod; however, it is possible to locate the punch or the resultant force within the shaded area.

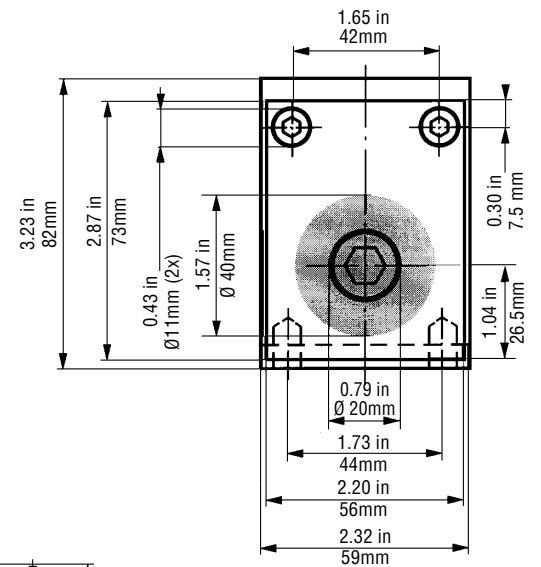

Part No.	Working Force		Stroke		B		C	
	N	Tons	mm	in	mm	in	mm	in
HCCU-015X024	15,000	1.69	24	0.94	133.5	5.26	94	3.70
HCCU-015X049	15,000	1.69	49	1.93	158.5	6.24	119	4.60

# Dimensions

## CC 040 Compact Cam Unit

# Dyne-A-Cam™ Series

## NITRO-CAM MANUAL

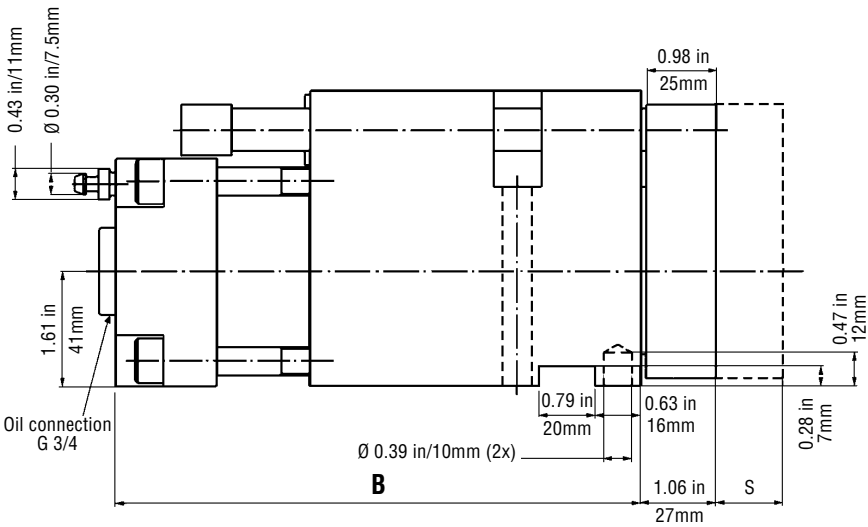
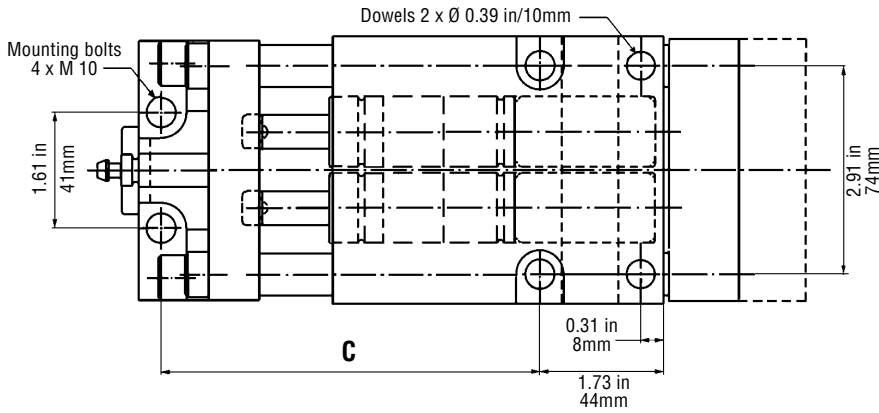

**!** It is recommended that the punch or resultant force (for multiple pierce applications) is located in the center of the piston rod; however, it is possible to locate the punch or the resultant force within the shaded area.

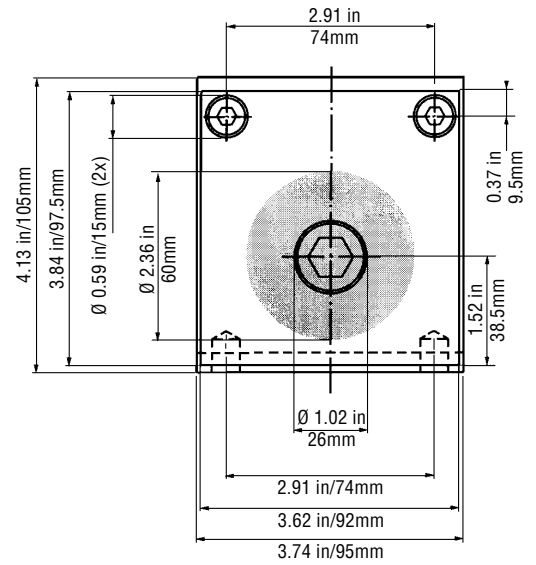

Part No.	Working Force		Stroke		B		C	
	N	Tons	mm	in	mm	in	mm	in
HCCU-040X024	40,000	4.5	24	0.94	187	7.36	135	5.31
HCCU-040X049	40,000	4.5	49	1.93	212	8.35	160	6.30
HCCU-040X099	40,000	4.5	99	3.90	262	10.31	210	8.27

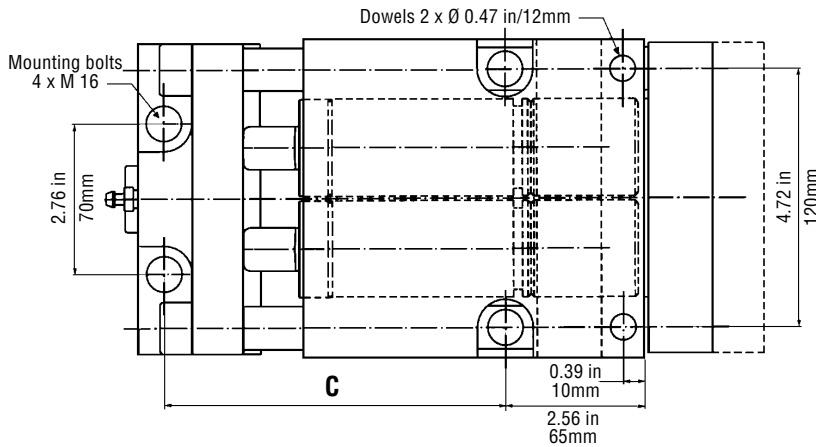

**!** It is recommended that the punch or resultant force (for multiple pierce applications) is located in the center of the piston rod; however, it is possible to locate the punch or the resultant force within the shaded area.

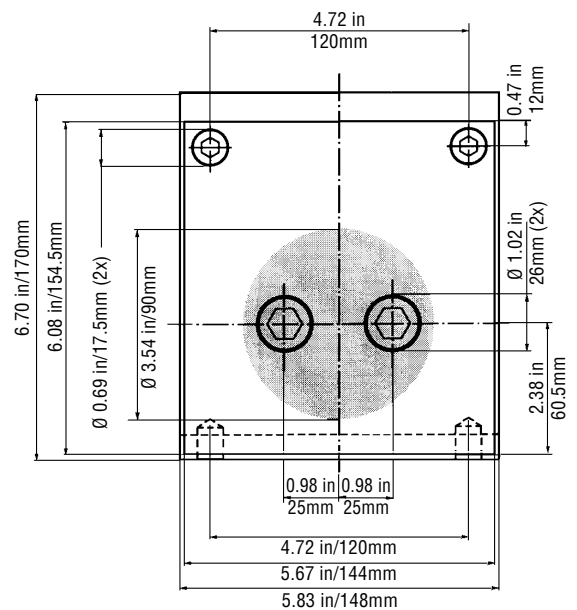
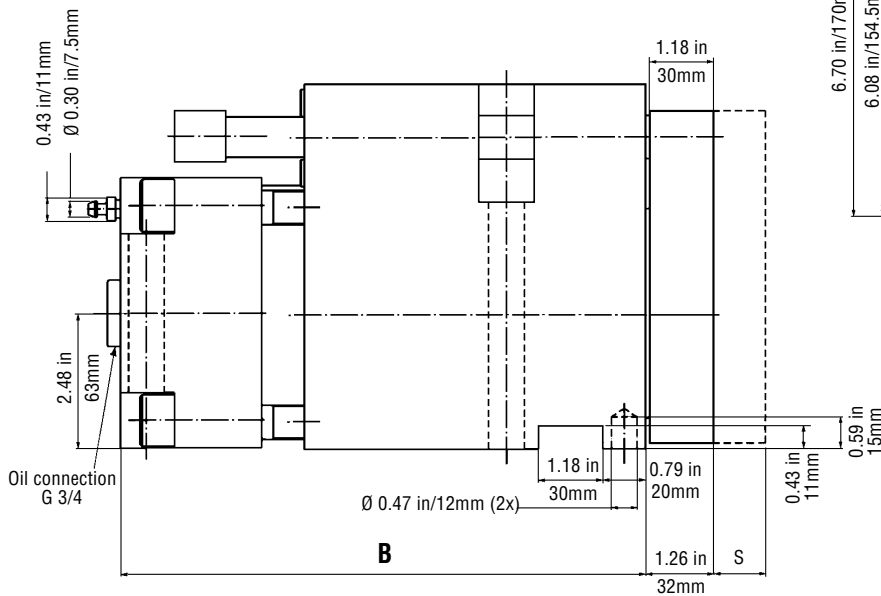

Part No.	Working Force		Stroke		B		C	
	N	Tons	mm	in	mm	in	mm	in
HCCU-090X024	90,000	10.12	24	0.94	236	9.29	159	6.26
HCCU-090X049	90,000	10.12	49	1.93	261	10.28	184	7.24
HCCU-090X099	90,000	10.12	99	3.90	311	12.24	234	9.21

# Dimensions

## HCP 015 Power Unit

**Dyne-A-Cam™ Series**  
NITRO-CAM MANUAL

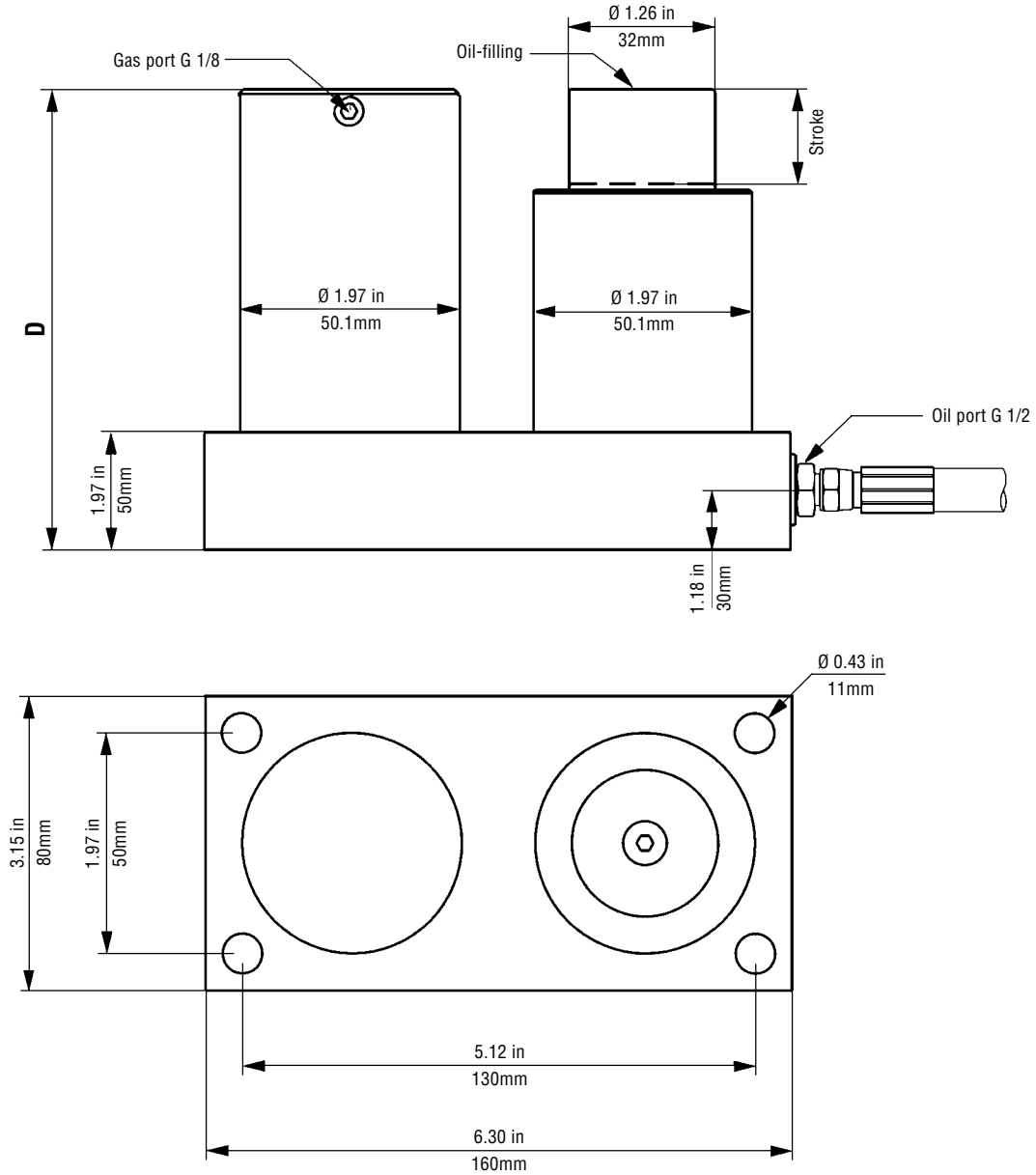

Part No.	Stroke		D		Force	
	in	mm	in	mm	Tons	N
HCPU-015X35	1.38	35	8.66	220	1.69	15,000
HCPU-015X60	2.36	60	10.63	270	1.69	15,000

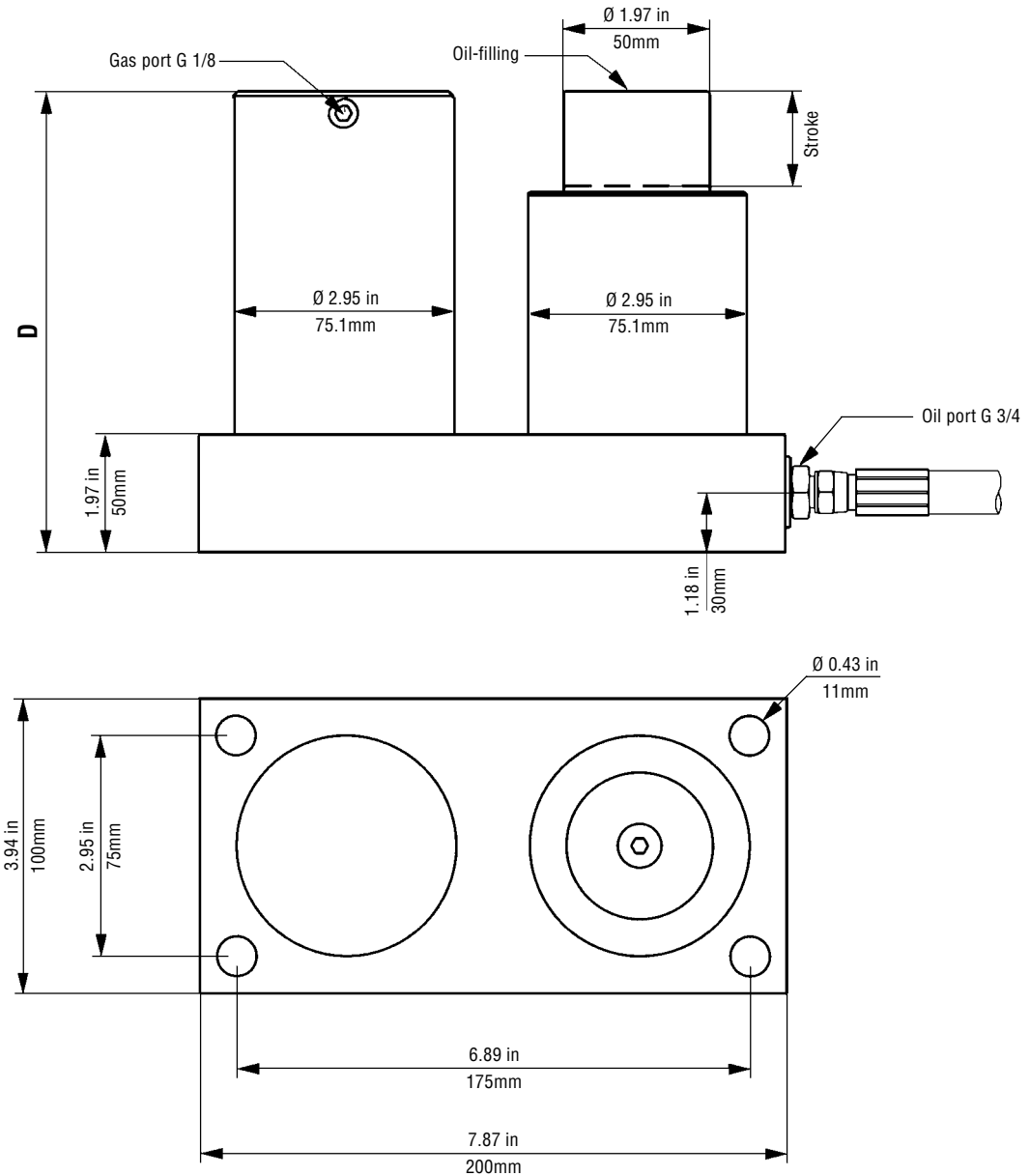

Part No.	Stroke		D		Force	
	in	mm	in	mm	Tons	N
HCPU-040X35	1.38	35	9.53	242	4.50	40,000
HCPU-040X60	2.36	60	11.50	292	4.50	40,000
HCPU-040X110	4.33	110	15.43	392	4.50	40,000

# Dimensions

## HCP 090 Power Unit

**Dyne-A-Cam™ Series**  
NITRO-CAM MANUAL

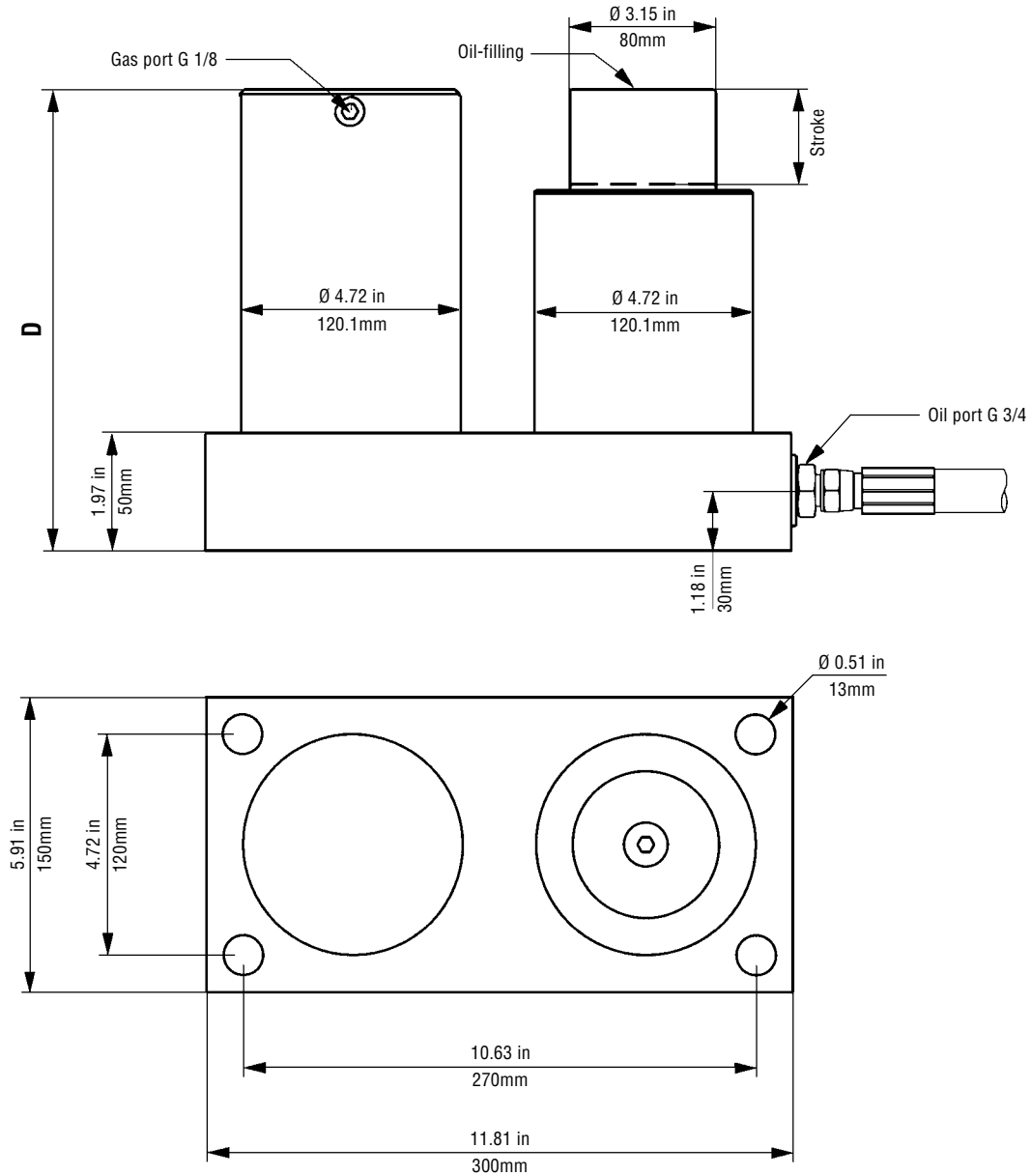

Part No.	Stroke		D	
	in	mm	in	mm
HCPU-090X35	1.38	35	10.87	276
HCPU-090X60	2.36	60	12.83	326
HCPU-090X110	4.33	110	16.77	426

**Hose, Straight-Straight Swivel**

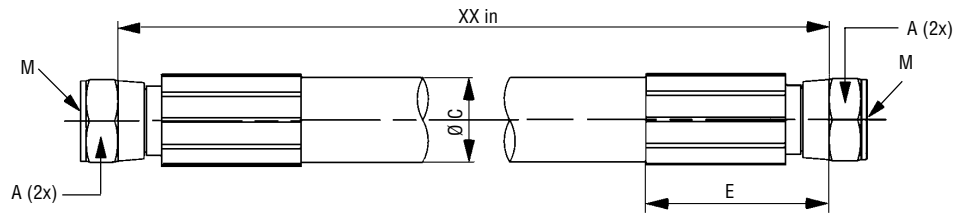

Power Unit	Hose dia	Thread M	Part No.	E		C		A	R min	
				mm	in	mm	in		mm	in
HCPU-015	1/2"	3/4 x 16 JIC	HCHA-015-180-XX	66	2.61	24	0.94	7/8	180	7.0
HCPU-040	3/4"	1-1/16 x 12 JIC	HCHA-040-180-XX	75	2.96	31	1.21	1-1/4	240	9.5
HCPU-090	1"	1-5/16 x 12 JIC	HCHA-090-180-XX	91	3.60	38	1.50	1-1/2	300	12.0

**Hose, Straight-45° Swivel**

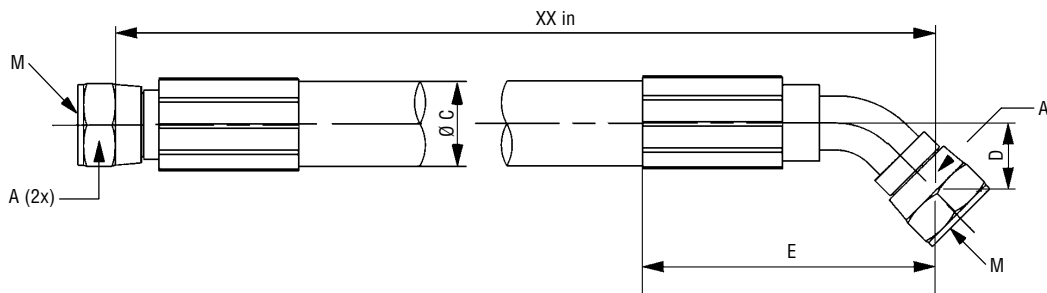

Power Unit	Hose dia	Thread M	Part No.	E		C		A	D		R min	
				mm	in	mm	in		mm	in	mm	in
HCPU-015	1/2"	3/4 x 16 JIC	HCHA-015-045-XX	73	2.87	24	0.94	7/8	14	0.55	180	7.0
HCPU-040	3/4"	1-1/16 x 12 JIC	HCHA-040-045-XX	105	4.15	31	1.21	1-1/4	31	1.22	240	9.5
HCPU-090	1"	1-5/16 x 12 JIC	HCHA-090-045-XX	124	4.90	38	1.50	1-1/2	37	1.44	300	12.0

**Hose, Straight-90° Swivel**

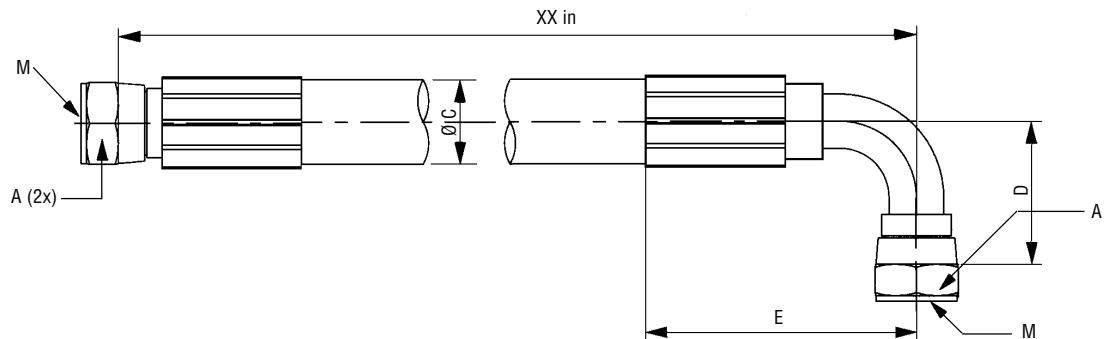

Power Unit	Hose dia	Thread M	Part No.	E		C		A	D		R min	
				mm	in	mm	in		mm	in	mm	in
HCPU-015	1/2"	3/4 x 16 JIC	HCHA-015-090-XX	67	2.64	24	0.94	13/16	28	1.09	180	7.0
HCPU-040	3/4"	1-1/16 x 12 JIC	HCHA-040-090-XX	92	3.62	31	1.21	1-1/4	62	2.44	240	9.5
HCPU-090	1"	1-5/16 x 12 JIC	HCHA-090-090-XX	110	4.32	38	1.50	1-1/2	74	2.93	300	12.0

# Dimensions

## Power Unit & Cam Unit Adapters

**Dyne-A-Cam™ Series**  
NITRO-CAM MANUAL

### Straight

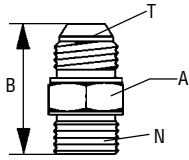

Adapter Part No.	Thread N	A	B		Thread T
			mm	in	
8-8F40MXS	G 1/2	30 mm	41.4	1.63	3/4-16
12-8F40MXS	G 1/2	30 mm	46.7	1.84	1-1/16-12
12F40MXS	G 3/4	36 mm	47.5	1.87	1-1/16-12
16-12F40MXS	G 3/4	36 mm	48.5	1.91	1-5/16-12

### 90° Elbow

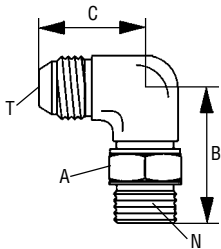

Adapter Part No.	Thread N	A	B		C		Thread T
			mm	in	mm	in	
8-8C40MXS	G 1/2	27 mm	43	1.69	33.7	1.33	3/4-16
12-8C40MXS	G 1/2	27 mm	49.5	1.95	42.2	1.66	1-1/16-12
12C40MXS	G 3/4	36 mm	49.5	1.95	42.2	1.66	1-1/16-12
16-12C40MXS	G 3/4	36 mm	52	2.05	46	1.81	1-5/16-12

### Run Tee

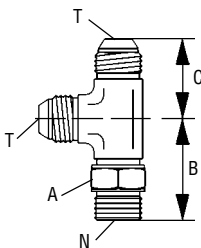

Adapter Part No.	Thread N	A	B		C		Thread T
			mm	in	mm	in	
8-8R40MXS	G 1/2	27 mm	43.2	1.70	31.8	1.25	3/4-16
12-8R40MXS	G 1/2	27 mm	49.3	1.94	42.2	1.66	1-1/16-12
16-8R40MXS	G 1/2	22 mm	52	2.05	46	1.81	1-5/16-12
12R40MXS	G 3/4	36 mm	49.5	1.95	42.2	1.66	1-1/16-12
16-12R40MXS	G 3/4	36 mm	52	2.05	46	1.81	1-5/16-12

### Branch Tee

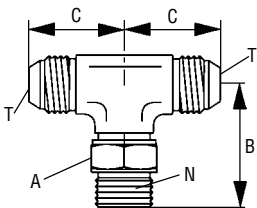

Adapter Part No.	Thread N	A	B		C		Thread T
			mm	in	mm	in	
8-8S40MXS	G 1/2	27 mm	43.2	1.70	31.8	1.25	3/4-16
12-8S40MXS	G 1/2	27 mm	49.3	1.94	42.2	1.66	1-1/16-12
16-8S40MXS	G 1/2	22 mm	52	2.05	46	1.81	1-5/16-12
12S40MXS	G 3/4	36 mm	49.5	1.95	42.2	1.66	1-1/16-12
16-12S40MXS	G 3/4	36 mm	52	2.05	46	1.81	1-5/16-12

**Union**

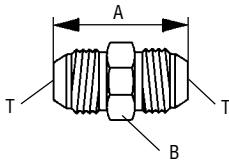

Adapter Part No.	A		B	Thread T
	mm	in		
8-HXTS	41	1.62	13/16	3/4-16
12-HXTS	55	2.16	1-1/8	1-1/16-12
16-HXTS	57	2.25	1-3/8	1-5/16-12

**Elbow**

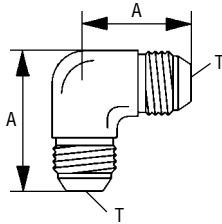

Adapter Part No.	A		Thread T
	mm	in	
8-EXTS	32	1.25	3/4-16
12-EXTS	42	1.66	1-1/16-12
16-EXTS	46	1.81	1-5/16-12

**Union Tee**

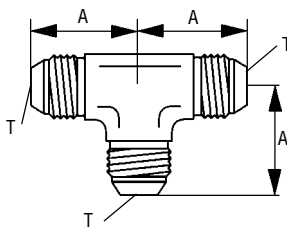

Adapter Part No.	A		Thread T
	mm	in	
8-JXTS	32	1.25	3/4-16
12-JXTS	42	1.66	1-1/16-12
16-JXTS	46	1.81	1-5/16-12

**Union Cross**

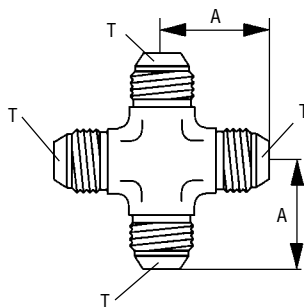

Adapter Part No.	A		Thread T
	mm	in	
8-KXTS	32	1.25	3/4-16
12-KXTS	42	1.66	1-1/16-12
16-KXTS	46	1.81	1-5/16-12

**Hyson™ Products**  
Associated Spring 

10367 Brecksville Road, Brecksville, Ohio 44141  
Toll Free 1-800-876-4976 • FAX: 440-838-7684  
[www.asbg.com](http://www.asbg.com)

---

**BASIC PRINCIPLES, DYNAMIC SOLUTIONS™**