

Nitrogen Gas Springs for High Speed Stamping

Tanker® XP Series

TNK 400HS

TNK 400HS Features

- Engineered for high performance, long service life.
- Life tested at speeds up to 600 spm.
- Dynamic lubrication circulates oil onto seal surfaces with every stroke.
- Improved service life compared to coil springs.
- Bore seal design for superior contamination resistance.
- Preloaded by gas pressure. Does not require compression in the die to preload.
- Available as self-contained or in a hoses system.
- Variety of mounting options provides flexibility in die design.

TNK 400HS Specifications

Pressure Medium	Nitrogen
Maximum Charging Pressure	150 bar/2175 psi
Maximum Operating Temperature	80°C/176°F
Maximum Utilized Stroke	100%
Maximum Piston Rod Velocity	35 m/min 115 ft/min
Seal Kit	Part No. 56-072-7000
Charge Fitting	Part No. T2-770-T3

TNK 400HS Dimensional Information

Part Number Model x Stroke	Stroke S		Maximum Contact Force		Y		L	
	mm	in	N	lbs	mm*	in**	mm	in
TNK 400 x .25HS	6.3	0.25	3940	885	82.5	3.25	76.2	3.00
TNK 400 x .50HS	12.7	0.50			114.3	4.50	101.6	4.00
TNK 400 x .75HS	19.0	0.75			146.1	5.75	127.0	5.00
TNK 400 x 1.00HS	25.4	1.00			152.0	6.00	127.0	5.00

*±0.25mm **± 0.010 in.

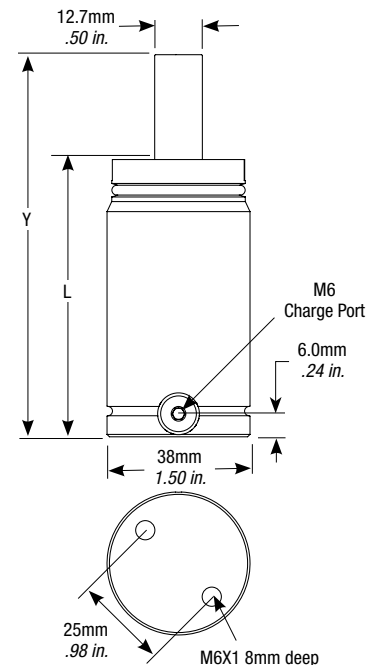

NOTE: Bottom mounting threads available in metric only.



10367 Brecksville Road
Brecksville, OH 44141 USA
Tel: 1-800-876-4976, 440-526-5900
Fax: 440-526-6807
Email: hyson@asbg.com
www.hysonproducts.com

3100 Mainway
Burlington, ONT L7M 1A3 Canada
Tel: 905-331-1311
Fax: 905-331-1342

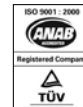

©Hyson Products 2009
TNK400HS1M0909

Bldv. Rogelio Gonzalez Caballero #500
Parque Industrial STIVA Aeropuerto
Apodaca, NL CP 66600 Mexico
Tel: 5281 8145-0570
Fax: 5281 8145-0571