

Service Instructions for Nitro-Dyne® & Nitro-Dyne® XP Manifold Cylinders DL, DLD, DLU, and DLDU Models - 6 Ton (8000)

Hyson™ Products
Associated Spring

Service Tools

Cylinder Model Sizes	Seal Kit P/N	Spanner Wrench	Socket Wrench	Cylinder Socket Wrench	Torque Spec. (ft-lb)
6 Ton & 8000	63-319-7000	FS-330	N/A	SW-6-TON	800 +/-80

⚠ Warnings

- Put on safety glasses and hearing protection before servicing any nitrogen gas spring system.
- Failure to exhaust all gas pressure prior to disassembly could result in serious injury.
- Do not depress piston rods with your hands directly. Place a block of wood between the rod and your hand. The piston rod may pop up after being manually depressed.
- The maximum charging pressure for a standard manifold is 103 bar (1500 psi). Higher pressure manifold systems do exist. Refer to the information tag attached to the manifold plate for maximum charge pressure information.
- Prior to pressurizing any manifold, inspect for proper assembly of cylinders and components. Cylinders and plugs are available in both English and metric thread types and may appear to be very similar in size. **Never mix thread types!** Intermixing English and metric thread types could result in serious injury. If there is any doubt about thread type, contact Hyson Products Customer Service at 1-800-876-4976.

Identifying Nitro-Dyne/ Nitro-Dyne XP models

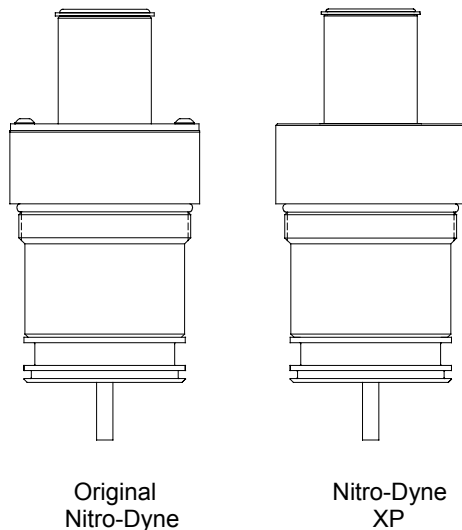

Discharging manifold systems

- Slowly open bleed down valve on control panel.
- When gauge reaches zero and the gas flow stops, depress piston rods.
- Close bleed down valve on control panel.

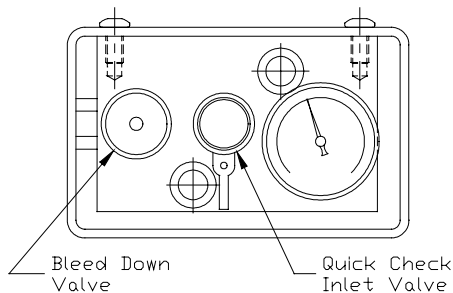

Inspection of manifold

- Verify all pressure has been exhausted from the system by following the discharging instructions.
- Unthread the manifold cylinders from the plate by using either the spanner, socket, or cylinder socket wrench. The pump bodies should come out with the cylinders, but if they do not, a ¼-20 threaded hole is provided in the pump body for removal purposes.
- Check the oil at the bottom of the cylinder cavities in the manifold. If contamination larger than 10 microns

is found and/or the oil viscosity is not between 450-550 centistokes, then the oil must be drained and discarded. Disassemble and thoroughly clean the manifold. After cleaning, reassemble the manifold and add the correct amount of new Hyson Products XP oil. The correct amount of oil is stamped on the manifold near the fill port. The sight glass will be ½ full after adding the XP oil.

- If the condition of the manifold and oil is acceptable, cover the port to prevent dirt from falling into the manifold plate.

Charging manifold systems

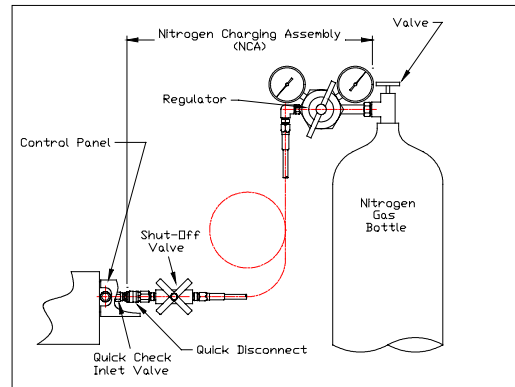

- Attach nitrogen charging assembly (NCA) to nitrogen gas bottle.
- Set NCA regulator to zero pressure.
- Close the shut-off valve on NCA hose.
- Close bleed down valve on control panel.
- Attach NCA quick disconnect to quick check inlet valve on control panel.
- Open valve on nitrogen gas bottle.
- Set desired charge pressure on NCA regulator.
- Slowly open shut-off valve on NCA hose.
- When correct pressure is obtained, close shut-off valve on NCA hose.
- Disconnect NCA from control panel.
- Replace protective cap on quick check inlet valve.
- Close valve on nitrogen bottle.
- Open shut-off valve on NCA hose to vent charging assembly.
- When gas flow stops, close NCA shut-off valve.

Verification of assembly (Leak test)

⚠ Warning: Prior to pressurizing any manifold, inspect for proper assembly of cylinders and components. Cylinders and plugs are available in both English and metric thread types and may appear to be very similar in size. **Never mix thread types!** Intermixing English and metric thread types could result in serious injury.

- Charge the manifold at least 69 bar (1000 psi) with a maximum of 103 bar (1500 psi). Refer to "Charging manifold systems" instructions above.
- Slip the test o-rings supplied in the seal kit over the piston rod and position the o-ring against the bottom of the rod retainer (2). **Note:** If piston rod does not have vent holes, this step may be omitted.
- Pour lightweight oil on each test o-ring and each rod scraper (7). If bubbles appear on any cylinder, nitrogen is leaking past the seal (14) or piston plug. **Note:** It may take several minutes for a small leak to be seen. If a leak is found, the cylinder would need to be discharged, disassembled, and inspected. A scratch on the cylinder body bore, piston rod seal surface or on the seal could be the cause.

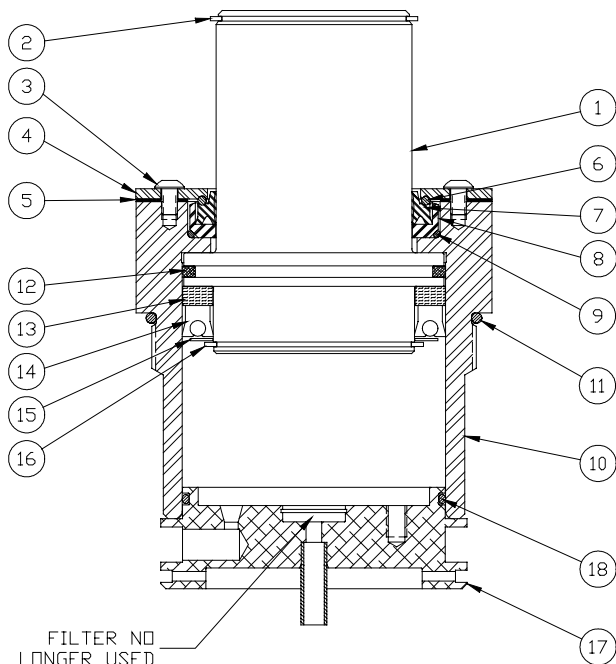

Original Nitro-Dyne

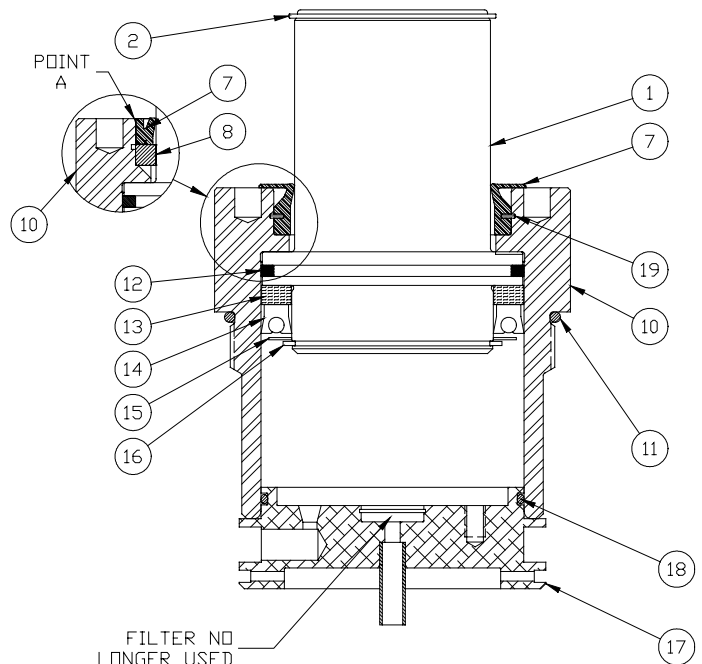

Nitro-Dyne XP

Disassembly

1. Remove the pump body (17) from the cylinder body (10).
2. Remove the rod retaining ring (2) from the piston rod (1). Remove the piston rod from the cylinder body (10).
3. Remove the seal retaining ring (16). The washer (15), seal (14), and piston bearing (13) can now be removed. **Note:** If using a screwdriver to pry the seal off the piston, be careful not to scratch the piston.
4. Remove the lubrication ring (12) from the piston.
- 5a. For original Nitro-Dyne only: Unscrew the button head cap screws (3). Remove the retaining cap (4), gasket (5), upper o-ring (6), scraper (7), floating bearing (8), and lower o-ring (9). **Note:** The DL 0.5 & DL 1 Series cylinders consist of only retaining cap, gasket, upper o-ring, and scraper.
- 5b. For Nitro-Dyne XP only: Remove rod scraper (7) and retaining ring (19). On older XP models, insert the end of a flat blade screwdriver between the cylinder body (10) and the rod scraper (7) at point A. Strike the screwdriver towards the center of the cylinder to deform the rod scraper (7). The scraper can then be pried out. **Note:** A new scraper will be supplied in the seal kit.
6. Remove the o-ring (18) from the pump body (17). If there is a filter and retaining ring in the pump body, remove and discard them.
- 7a. For original Nitro-Dyne only: Save the cylinder body (10), piston rod (1), pump body (17) and retaining cap (4). All other parts are included in the seal kit and can be discarded.
- 7b. For Nitro-Dyne XP only: Save the cylinder body (10), piston rod (1) and pump body (17). All other parts are included in the seal kit and can be discarded.

Inspection

8. Inspect the cylinder body (10) and piston rod (1). If contamination such as drawing fluid, metal shavings, or other debris is found, it is possible that the contamination may have penetrated into the piston rod assembly. In this event, it may be necessary to rebuild the piston rod assembly. The tools and components needed to rebuild the piston rod assembly are not included in the seal kit. Contact Hyson Products Customer Service for additional instructions on servicing the piston rod assembly. **Note:** Under normal conditions without contamination, it is not necessary to rebuild the piston rod assembly.
- 9a. For original Nitro-Dyne only: Clean the cylinder body (10), piston rod (1), pump body (17) and retaining cap (4).
- 9b. For Nitro-Dyne XP only: Clean the cylinder body (10), piston rod (1) and pump body (17).

10. Visually inspect all components. The inner diameter of the cylinder and the surface of the piston where the seal rests are critical. Any scratches or dents will lead to premature leakage. If defects exist, replace the parts.

Assembly

11. Unpack and inspect the seal kit. The seal kit includes components to rebuild the original Nitro-Dyne and Nitro-Dyne XP cylinders; therefore some components will not be used.
12. The seal kit contains Nitro-Dyne® Lube XP-33. There is a line drawn on the bottle indicating 25% of the oil volume. The 25% (above the line) is used as assembly oil. The remaining oil is poured into the manifold.
- 13a. For original Nitro-Dyne only: Assemble the rod scraper assembly. Lubricate the lower o-ring (9), floating bearing (8), and upper o-ring (6). Place the lower o-ring (9) into the counterbored pocket located at the top of the cylinder body (10). Place the floating bearing (8) over the o-ring. Insert the scraper (7) into the floating bearing (8). Place the upper o-ring (6) onto the scraper assembly. Position the gasket (5) on the top surface of the cylinder. Position the retaining cap (4) so the o-ring groove is facing downward. Attach the retaining cap (4) using the new nylon patch screws (3), being careful not to pinch the upper o-ring (6). Do not tighten the screws. **Note:** The DL 0.5 & DL 1 Series cylinders consist of only retainer cap, gasket, upper o-ring, and scraper.
- 13b. For Nitro-Dyne XP only: Install the retaining ring (19) and rod scraper (7) into the cylinder body (10). The rod bearing (8) is no longer used in the 6 ton model XP cylinders.
14. Insert the lubrication ring (12) onto the piston rod (1). **Note:** The lubrication ring replaces the bore wiper.
15. Liberally lubricate the piston rod and all components you will install on the piston. Install the piston bearing (13), seal (14), washer (15), and retaining ring (16).
16. Liberally lubricate the inner diameter of the cylinder body (10). Push the piston rod (1) into the cylinder body (10) to the fully extended position.
17. Attach the rod retaining ring (2) in the groove located at the top of piston rod.
- 18a. For original Nitro-Dyne only: Push the rod down and tighten the screws (3).
- 18b. For the Nitro-Dyne XP only: Push the rod down.
19. Liberally lubricate the o-ring (18) and assemble on pump body. The filter and retaining ring are no longer used in the 6 ton model DL cylinder assembly.
20. Lubricate the cylinder body (10) at open end of the bore and insert the pump body (17).
21. Lubricate o-ring (11) and install on cylinder body (10).