

**Service Instructions for
Nitro-Dyne® & Nitro-Dyne® XP Manifold Cylinders
DLB Models**

Service Tools

Model	Seal Kit P/N	Spanner Wrench	Socket Wrench	Cylinder Socket Wrench	Torque Spec. (ft-lb)
DLB 2.5 B, DLB 2.5 P	DLB-209-7000 B DLB-209-7000 P	FS-300	SW-209	SW-2.5	350 +/-35

⚠ Warnings

- Put on safety glasses and hearing protection before servicing any nitrogen gas spring system.
- Failure to exhaust all gas pressure prior to disassembly could result in serious injury.
- Do not depress piston rods with your hand directly. Place a block of wood between the rod and your hand. The piston rod may pop up after being manually depressed.
- The maximum charging pressure for a standard manifold is 103 bar (1500 psi). Higher pressure manifold systems do exist. Refer to the information tag attached to the manifold plate for maximum charge pressure information.
- Prior to pressurizing any manifold, inspect for proper assembly of cylinders and components. Cylinders and plugs are available in both English and metric thread types and may appear to be very similar in size. **Never mix thread types!** Intermixing English and metric thread types could result in serious injury. If there is any doubt about thread type, contact Hyson Products' Customer Service at 1-800-876-4976.

Identifying Nitro-Dyne/ Nitro-Dyne XP models

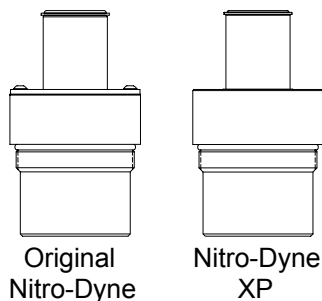

Discharging manifold systems

1. Slowly open bleed down valve on control panel.
2. When gauge reaches zero and the gas flow stops, depress piston rods.
3. Close bleed down valve on control panel.

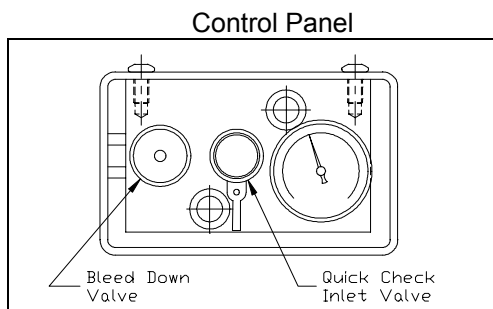

Charging manifold systems

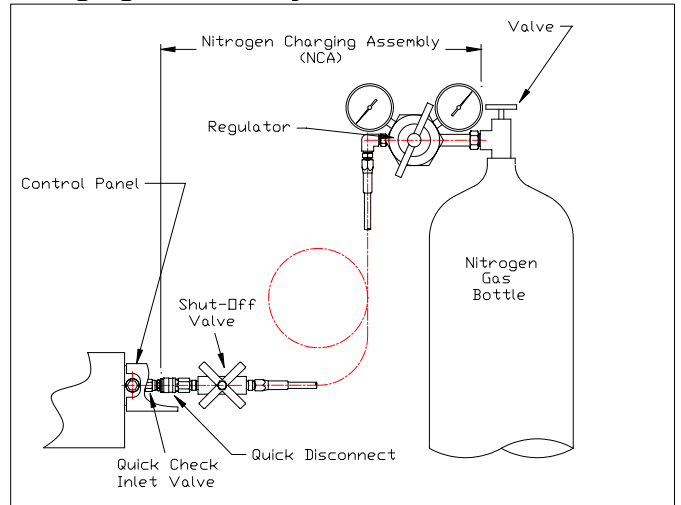

1. Attach Nitrogen Charging Assembly (NCA) to nitrogen gas bottle.
2. Set NCA regulator to zero pressure.
3. Close the shut-off valve on NCA hose.
4. Close bleed down valve on control panel.
5. Attach NCA quick disconnect to quick check inlet valve on control panel.
6. Open valve on nitrogen gas bottle.
7. Set desired pressure on NCA regulator.
8. Slowly open shut-off valve on NCA hose.
9. When correct pressure is obtained, close valve on NCA hose.
10. Disconnect NCA from control panel.
11. Replace protective cap on quick check inlet valve.
12. Close valve on nitrogen bottle.
13. Open shut-off valve on NCA hose to vent charging assembly.
14. When gas flow stops, close NCA shut-off valve.

Verification of assembly (Leak test)

1. Charge the manifold to at least 69 bar (1000 psi) with a maximum of 103 bar (1500 psi). Refer to charging instructions.
2. Slip the test o-ring supplied in the seal kit over the piston rod and position it against the bottom of the rod retainer (2). **Note:** If piston rod does not have vent holes, this step may be omitted.
3. Pour lightweight oil on the test o-ring and the rod scraper (7). If bubbles appear, nitrogen is leaking past the seal (14) or past the plug in the bottom of the piston rod. **Note:** It may take several minutes for a small leak to be seen. If a leak is found, the cylinder needs to be discharged, disassembled, and inspected. A scratch on the cylinder body bore, rod or seal could be the cause.

Original Nitro-Dyne

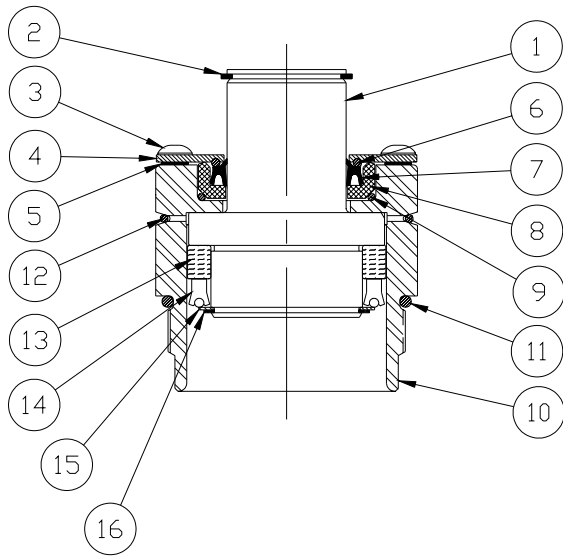

Nitro-Dyne XP

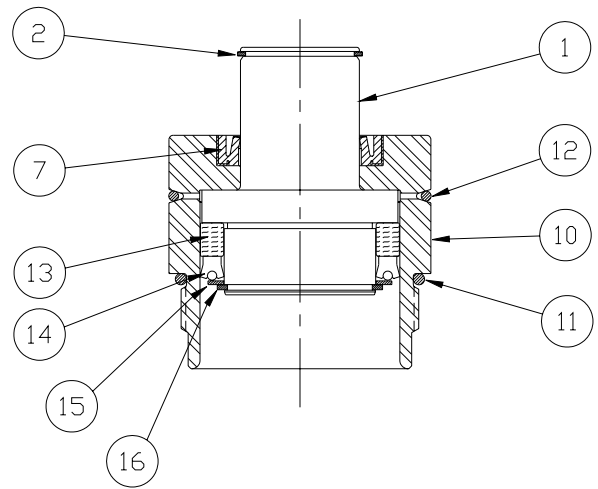

Disassembly

1. Verify all pressure has been exhausted from the system by following the discharging instructions.
2. Unthread the manifold cylinder from the plate by using either the spanner, socket, or cylinder socket wrench. Once the cylinder is removed from the plate, cover the port to prevent dirt from falling into the manifold plate.
3. Remove the o-ring (12) from the body (10).
4. Remove the rod retaining ring (2) from the piston rod (1). Remove the piston rod from the cylinder body (10).
5. Remove the seal retaining ring (16). The washer (15), seal (14), and piston bearing (13) can now be removed. **Note:** If using a screwdriver to pry the seal off the piston, be careful not to scratch the piston.
- 6a. For original Nitro-Dyne only: Unscrew the button head cap screws (3). Remove the retaining cap (4), gasket (5), upper o-ring (6), scraper (7), floating bearing (8), and lower o-ring (9).
- 6b. For Nitro-Dyne XP only: Insert the end of a flat blade screwdriver between the cylinder body (10) and the rod scraper (7) at point A. Strike the screwdriver towards the center of the cylinder to deform the rod scraper (7). The scraper can then be pried out. **Note:** A new scraper is supplied in the seal kit.
- 7a. For original Nitro-Dyne only: Save the cylinder body (10), piston rod (1), and retaining cap (4). All other parts are included in the seal kit and can be discarded.
- 7b. For Nitro-Dyne XP only: Save the cylinder body (10) and piston rod (1). All other parts are included in the seal kit and can be discarded.

Inspection

8. Inspect the cylinder body (10), piston rod (1) and manifold plate. If contamination such as drawing fluid, metal shavings, or other debris is found, it is possible that the contamination may have penetrated into the piston rod assembly. In this event it may be necessary to rebuild the piston rod assembly. The tools and components needed to rebuild the piston rod assembly are not included in the seal kit. Contact Hyson Products Customer Service (1-800-876-4976) for additional instructions on servicing the piston rod assembly. **Note:** Under normal conditions without contamination, it is not necessary to rebuild the piston rod assembly.
- 9a. For original Nitro-Dyne only: Clean the cylinder body (10), piston rod (1), and retaining cap (4).

- 9b. For Nitro-Dyne XP only: Clean the cylinder body (10) and piston rod (1).
10. Visually inspect all components. The inner diameter of the cylinder and the surface of the piston where the seal rests are critical. Any scratches or dents will lead to premature leakage. If defects exist, replace the parts.

Assembly

11. Unpack the seal kit. The seal kit part number includes components to rebuild both the original Nitro-Dyne and Nitro-Dyne XP; therefore some components will not be used.
12. The seal kit contains Nitro-Dyne® Lube XP-206. This is used as assembly oil only. Discard unused oil.
- 13a. For original Nitro-Dyne only: Assemble the rod scraper assembly. Lubricate the lower o-ring (9), floating bearing (8), and upper o-ring (6). Place the lower o-ring (9) into the counter-bored pocket located at the top of the cylinder body (10). Place the floating bearing (8) over the o-ring. Insert the scraper (7) over the rod and press it into the floating bearing. Place the upper o-ring (6) onto the scraper assembly. Position the gasket (5) on the top surface of the cylinder. Position the retaining cap (4) so the o-ring groove is facing downward. Attach the retaining cap (4) using the new nylon patch screws (3), being careful not to pinch the upper o-ring (6). Do not tighten the screws.
- 13b. For Nitro-Dyne XP only: Press the rod scraper (7) into the cylinder body (10).
14. Insert the o-ring (12) onto the V-groove on the body (10). (Refer to either the Nitro-Dyne or Nitro-Dyne XP drawing above.) **Note:** The o-ring will be stretched to fit in the groove.
15. Liberally lubricate the piston rod and all components to be installed on the piston. Install the piston bearing (13), seal (14), washer (15), and retaining ring (16).
16. Liberally lubricate the inner diameter of the cylinder body (10). Push the piston rod (1) into the cylinder body (10) to the fully extended position.
17. Attach the rod retaining ring (2) in the groove located at the top of piston rod.
18. Liberally lubricate o-ring (11) and install onto the body (10) being careful not to cut the o-ring on the body threads.
- 19a. For original Nitro-Dyne only: Push the rod down and tighten the screws (3).
- 19b. For the Nitro-Dyne XP only: Push the rod down.