

Service Tools

Model	Seal Kit P/N	Spanner Wrench	Torque Spec.(lb.-ft.)
SB 1	16-150-7000	FS-100	220 +/-22
SB 2.5	16-209-7000	FS-100	350 +/-35
SB 4	16-262-7000	FS-434	800 +/-80
SB 6	16-319-7000	FS-330	800 +/-80

⚠ Warnings

- Put on safety glasses and hearing protection before servicing any nitrogen gas spring system.
- Failure to exhaust all gas pressure prior to disassembly could result in serious injury.
- Do not depress piston rods with your hand directly. Place a block of wood between the rod and your hand. The piston rod may pop up after being manually depressed.
- The maximum charging pressure for a standard manifold is 103 bar (1500 psi). Higher pressure manifold systems do exist. Refer to the information tag attached to the manifold plate for maximum charge pressure information.
- Prior to pressurizing any manifold, inspect for proper assembly of cylinders and components. Cylinders and plugs are available in both English and metric thread types and may appear to be very similar in size. **Never mix thread types!** Intermixing English and metric thread types could result in serious injury. If there is any doubt about thread type, contact Hyson Products' Customer Service at 1-800-876-4976.

Discharging manifold systems

1. Slowly open bleed down valve on control panel.
2. When gauge reaches zero and the gas flow stops, depress piston rods.
3. Close bleed down valve on control panel.

Control Panel

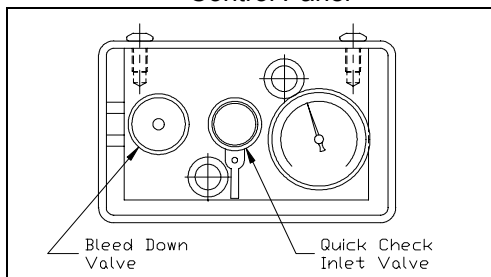

Charging manifold systems

1. Attach Nitrogen Charging Assembly (NCA) to nitrogen gas bottle.
2. Set NCA regulator to zero pressure.

3. Close the shut-off valve on NCA hose.
4. Close bleed down valve on control panel.
5. Attach NCA quick disconnect to quick check inlet valve on control panel.
6. Open valve on nitrogen gas bottle.
7. Set desired pressure on NCA regulator.
8. Slowly open shut-off valve on NCA hose.
9. When correct pressure is obtained, close valve on NCA hose.
10. Disconnect NCA from control panel.
11. Replace protective cap on quick check inlet valve.
12. Close valve on nitrogen bottle.
13. Open shut-off valve on NCA hose to vent charging assembly.
14. When gas flow stops, close NCA shut-off valve.

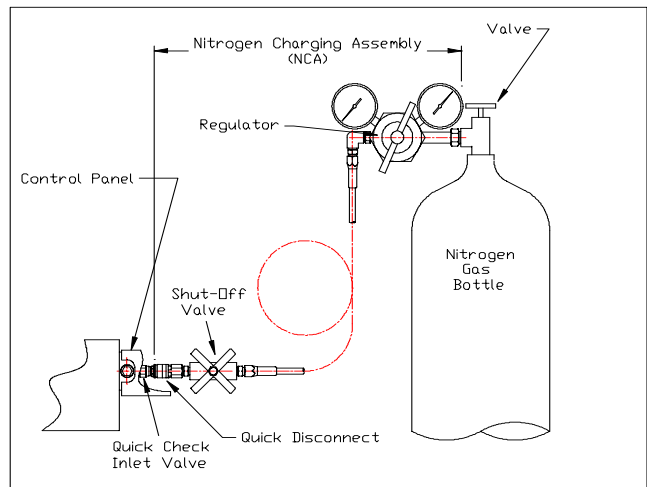

Verification of Assembly (Leak test)

1. Charge the manifold to at least 69 bar (100 psi). Refer to charging instructions.
2. Pour lightweight oil on the rod scraper (8). If bubbles appear, nitrogen is leaking past the seal (5). **Note:** It may take several minutes for a small leak to be seen. If a leak is found, the cylinder needs to be discharged, disassembled, and inspected. A scratch on the cylinder body bore, rod or seal could be the cause.

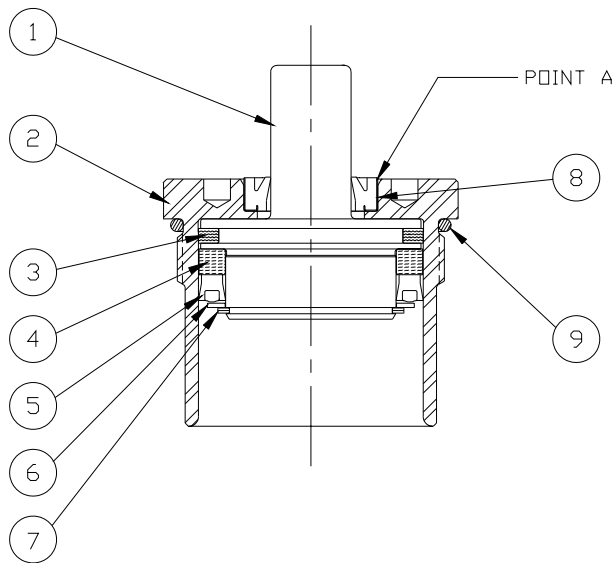

Disassembly

1. Verify all pressure has been exhausted from the system by following the discharging instructions.
2. Unthread the manifold cylinder from the plate by using the spanner wrench. Once the cylinder is removed from the plate, cover the port to prevent dirt from falling into the manifold plate.
3. Remove the piston rod (1) from the cylinder body (2).
4. Remove o-ring (9) from the cylinder body. **Note:** If using a screwdriver to lift the o-ring, be careful not to scratch the cylinder body seal surface.
5. Remove the seal retaining ring (7). The washer (6), seal (5), and piston bearing (4) can now be removed. **Note:** If using a screwdriver to pry the seal off the piston, be careful not to scratch the piston.
6. Remove the wiper (3).
7. Insert the end of a flat blade screwdriver between the cylinder body (2) and the rod scraper (8) at point A. Strike the screwdriver towards the center of the cylinder to deform the rod scraper (8). The scraper can then be pried out. **Note:** A new scraper is supplied in the seal kit.
8. Save the cylinder body (2) and piston rod (1). All other parts are included in the seal kit and can be discarded.
9. Visually inspect all components. The inner diameter of the cylinder and the surface of the piston where the seal rests are critical. Any

scratches or dents will lead to premature leakage. If defects exist, replace the parts.

Inspection

10. Inspect the cylinder body (2), piston rod (1) and cavities in manifold plate. If contamination such as drawing fluid, metal shavings, or other debris is found, the manifold must be cleaned.
11. Clean the cylinder body (2) and piston rod (1).
12. Unpack the seal kit.

Assembly

13. The seal kit contains Nitro-Dyne® Lube XP-206. This is used as assembly oil. The remaining oil is poured into the manifold.
14. Press the rod scraper (8) into the cylinder body (2).
15. Liberally lubricate the o-ring (9) and carefully install on cylinder body. If the o-ring is cut on the threads, it will not seal properly.
16. Insert the wiper (3) onto the piston.
17. Liberally lubricate the piston rod and all components you will install on the piston. Install the piston bearing (4), seal (5), washer (6), and retaining ring (7).
18. Liberally lubricate the inner diameter of the cylinder body (2). Push the piston rod (1) into the cylinder body (2) to the fully extended position.
19. Push the rod down.
20. Install cylinder in manifold or test fixture to proper torque.
21. Leak test cylinder per Verification of Assembly.