

**Service Tools**

Model	Seal Kit P/N	Tool Kit	Service Gauge	Service Fitting	Valve Tool
TNK 3	57-150-7000	T2TK	MGA-3000	T2-770-4-L	T2TK-IN
TNK 5.5	57-209-7000				
TNK 9	57-262-7000				

**Warnings**

- Failure to exhaust all gas pressure prior to disassembly could result in serious injury.
- Maximum charging pressure is 150 bar (2175 psi).
- Never clamp the tank directly in a vise.

**Discharging self-contained springs**

1. Remove the charge port plug (20).
2. Close the bleed down valve on the MGA-3000 service gauge assembly. Thread the T2-770-4-L service fitting into the charge port. Attach the MGA-3000 to the T2-770-4-L to depress the valve. *Alternative method: Thread the T2TK-IN inlet valve tool into the charge port to depress the valve.*
3. To verify all pressure has been exhausted, manually depress the piston rod into the tank by striking the top of the rod with a rubber mallet.

**Charging self-contained springs**

1. Close the bleed down valve on the MGA-3000 service gauge assembly. Thread the T2-770-4-L service fitting

Into the charge port. Attach the MGA-3000 to the T2-770-4-L.

2. Open the valve on the nitrogen bottle and slowly charge the spring to the desired pressure.
3. Close the valve to the nitrogen bottle. Disconnect the service gauge assembly and unscrew the service fitting from the spring.
4. Thread the charge port plug (20) into the port.

**Verification of assembly (Leak test)**

1. Charge the gas spring to at least 35 bar (500 psi). Refer to charging instructions.
2. After charging, vent the trapped air behind the scraper (4). Gently vent the air behind the scraper (4) by placing a small screwdriver at point B and pulling radially outward to allow the air to flow past.
3. Pour lightweight oil on the rod scraper. If bubbles appear, nitrogen is leaking past the seal (13) or the o-ring (7) and back-up ring (10). **Note:** It may take several minutes for a small leak to be seen. If a leak is found, the spring needs to be discharged, disassembled, and inspected. A scratch on the cylinder tube surface or seal could be the cause.

**Instructions for Super Tanker models only**

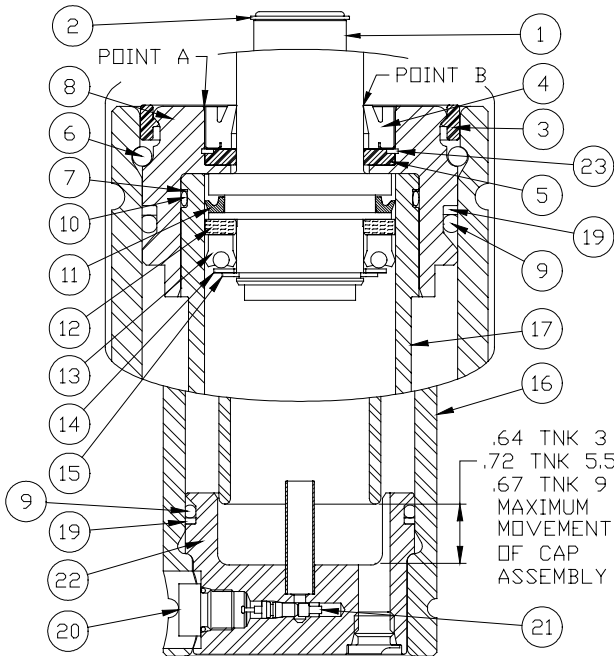

**Disassembly**

1. Verify all pressure has been exhausted from the spring by following the discharging instructions.
2. Remove the dust cover (3).

3. Using a socket and rubber mallet, tap the cap (8) into the cylinder (16) until the lock ring (6) is exposed. **Note:** The cap and sleeve assembly will only move a short distance. See cylinder cross-section.
4. Remove the lock ring (6).

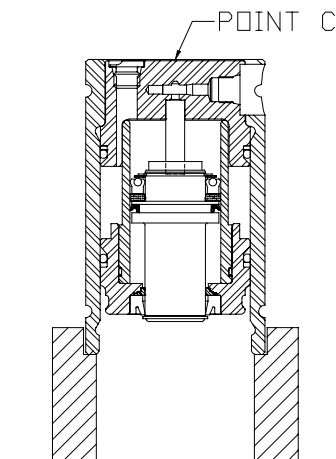

5. Remove the cap assembly (8) by pulling the piston rod (1) out of the cylinder, or affix the spring as shown above and press on the base (22) at point C.
6. Remove the base assembly (22).
7. Unwrap the rod retaining ring (2) from the piston rod (1). Remove the piston rod from the cap (8) and sleeve (17).
8. Remove the cylinder sleeve (17) from the cap (8).

## Service Instructions for Super Tanker® Gas Springs (TNK 3, 5.5 & 9)

9. Remove the o-ring (9) and back-up ring (19) from the

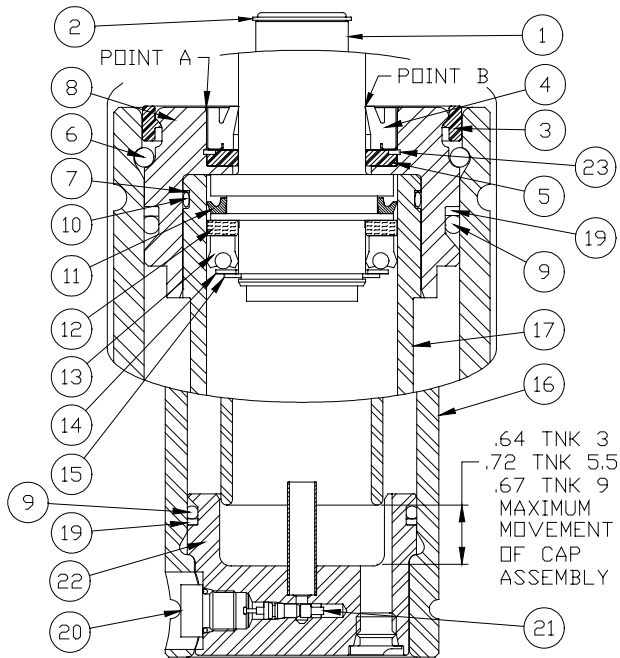

rod cap (8).

10. Remove the seal retainer ring (15). The washer (14), seal (13), and piston bearing (12) can now be removed. **Note:** If using a screwdriver to pry the seal off the piston, be careful not to scratch the piston.
11. Remove the bore scraper (11) from the piston.
12. Insert the end of a flat blade screwdriver between the rod cap (8) and the rod scraper (4) at point A. Strike the screwdriver towards the center of the cylinder to deform the rod scraper (4). The scraper can then be pried out. **Note:** A new scraper is supplied in the seal kit.
13. Remove retaining ring (23) [TNK 5.5 & 9 only]. Remove rod bearing (5).
14. Remove the o-ring (9), back-up ring (19) and valve (21) from the base (22).
15. Save the tank (16), sleeve (17), rod cap (8), base (22), valve (21), port plug (20), and piston rod (1). All other parts are included in the seal kit and can be discarded.

### Inspection

16. Clean the tank (16), sleeve (17), rod cap (8), base (22), port plug (20) and piston rod (1).
17. Visually inspect all components. The inner diameter of the sleeve and the surface of the piston where the seal rests are critical. Any scratches or dents will lead to premature leakage. If defects exist, replace the parts.

### Assembly

18. Unpack the seal kit. The seal kit includes components to rebuild the Super Tanker and the Tanker® XP; therefore some components will not be used.
19. The seal kit contains Nitro-Dyne® Tanker® Lube XP-33. Use a portion of the lubricant as assembly oil. The remaining oil is poured into the tank.
20. Install the bearing (5) into the rod cap (8). Install retaining ring (23) [TNK 5.5 & 9 only]. Press the rod scraper (4) into the rod cap (8).
21. Insert the bore scraper (11) onto the piston rod so the open end faces the rod (refer to drawing).

22. Liberally lubricate the piston rod and all components you will install on the piston. Insert the piston bearing (12), seal (13), washer (14), and retainer ring (15).
23. Liberally oil the o-ring (10) and install it onto the sleeve (17). Insert the back-up ring (7) onto the sleeve above the o-ring. **Note:** Refer to drawing for o-ring and back-up ring positions.
24. Press the sleeve assembly (17) into the rod cap (8).
25. Liberally oil the inner diameter of the sleeve (17) and the outside diameter of the seal (13). Press the piston rod (1) into the sleeve and rod cap assembly.
26. Attach the rod retaining ring (2) in the groove located at the top of piston rod (1).
27. Install one of the o-rings (9) and back-up rings (19) on the rod cap (8).
28. Install the other o-ring (9) and back-up ring (19) on the base (22).
29. Insert the base assembly into the tank (16). Tap down the base assembly with a socket and rubber mallet until the base seated. **Note:** the base (22) will not extend beyond the tank end (16) but should be almost flush. Rotate the base (22) to align the port in the center of the tank opening.
30. Pour the remaining XP-33 lubricant into the tank (16). Insert the cap assembly into the tank (16). Tap down the cap assembly with a socket and rubber mallet so that the lock ring groove in the tank is in view.
31. Fit the lock ring (6) into the lock ring groove by pushing one end of the ring into the groove and knocking the other end with a mallet until it snaps into place. You can hear a clicking sound when the ring snaps into place.
32. Pull out the piston rod (1) until the cap (8) is in line with the tube end.



**Warning:** If the cap cannot be pulled in line with or extends out past the upper tank end, the spring is not assembled correctly. Gas should not be put into the spring until the cap is in line with the tank end. Pressurizing an incorrectly assembled spring could result in serious injury.

**Hyson™ Products**  
Associated Spring

10367 Brecksville Road  
Brecksville, OH 44141 USA  
Toll Free: 1-800-876-4976  
Tel: 440-526-5900  
Fax: 440-838-7684  
Email: hyson@asbg.com

©Hyson Products 2004  
Part No.: ST3-9 0504